

Single Worm Reducer
Single Worm Reducer
Single Worm Reducer

Single

SAMYANG

Single Worm Geared Motor
Single Worm Geared Motor
Single Worm Geared Motor

중실축 WORM REDUCER

Single Worm Reducer & Geared Motor

I

Double Worm Reducer & Geared Motor

II





Top Flat Worm Reducer

III

STD Economy Worm Reducer

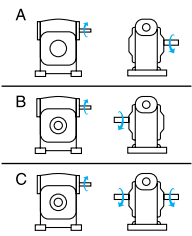
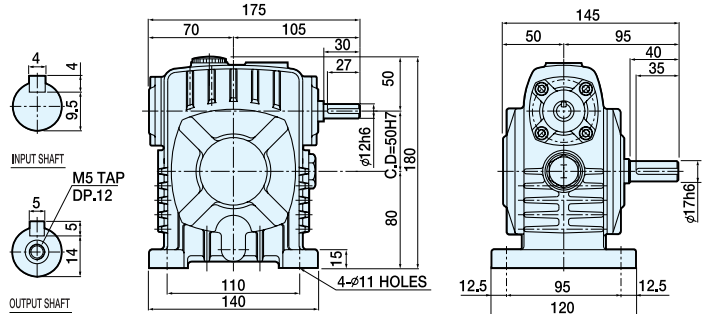
IV

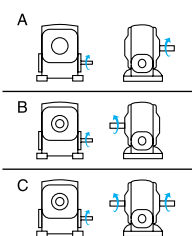
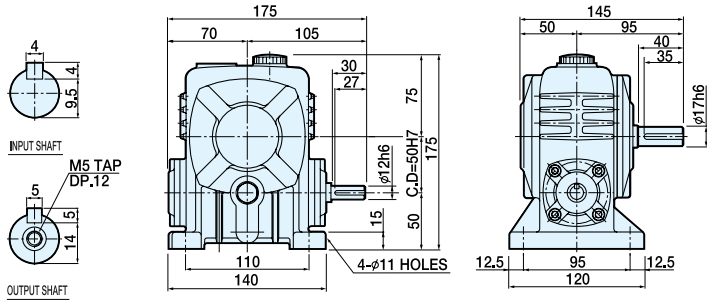
Single Worm Reducer/1단 웜 감속기

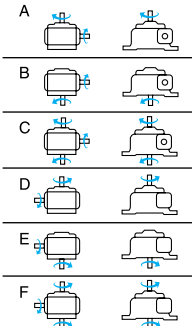
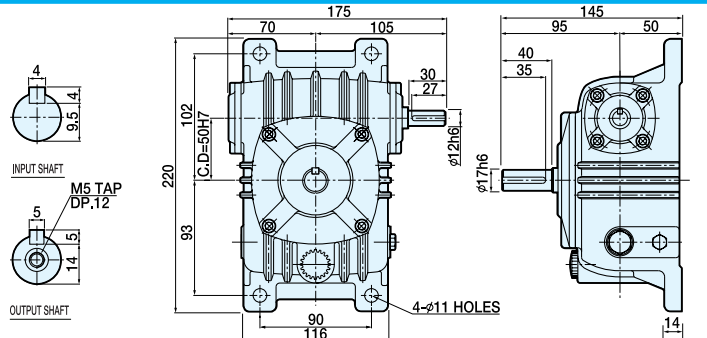



MODEL	축배치 및 회전방향	도면
 <p>WU-50 W ≈ 7 kg</p>		
 <p>WB-50 W ≈ 7 kg</p>		
 <p>WV-50 W ≈ 7 kg</p>		

전동능력표

수치는 1일 8~10시간 연속 운전이고 균일 하중의 수치입니다.

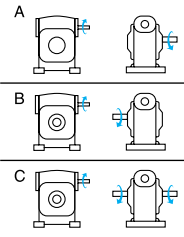
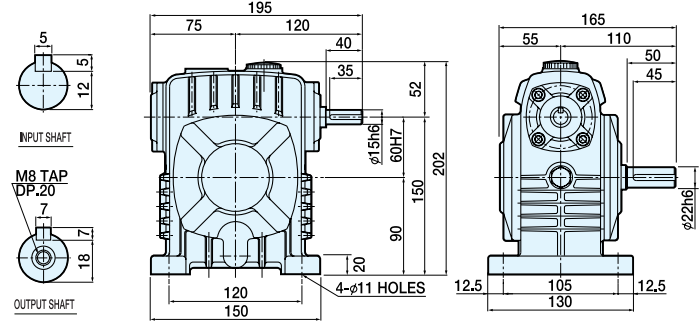
INPUT rpm RATIO	1800				1500				1200			
	INPUT HP	OUTPUT HP	OUTPUT T kgf-m	OUTPUT O.H.L kgf	INPUT HP	OUTPUT HP	OUTPUT T kgf-m	OUTPUT O.H.L kgf	INPUT HP	OUTPUT HP	OUTPUT T kgf-m	OUTPUT O.H.L kgf
1/10	1.43	1.15	4.59	100	1.31	1.03	4.94	107	1.16	0.90	5.40	115
1/15	1.07	0.81	4.89	115	0.97	0.73	5.22	115	0.82	0.60	5.43	115
1/20	0.65	0.48	3.85	115	0.58	0.43	4.13	115	0.51	0.37	4.48	115
1/25	0.76	0.54	5.40	115	0.53	0.37	4.51	115	0.47	0.32	4.86	115
1/30	0.68	0.45	5.43	115	0.58	0.37	5.43	115	0.48	0.30	5.43	115
1/40	0.44	0.28	4.50	115	0.40	0.25	4.80	115	0.35	0.21	5.16	115
1/50	0.39	0.23	4.65	115	0.35	0.20	4.94	115	0.31	0.17	5.29	115
1/60	0.31	0.19	4.35	115	0.28	0.16	4.60	115	0.24	0.12	4.87	115

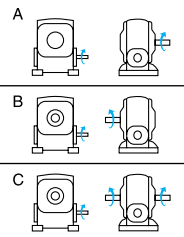
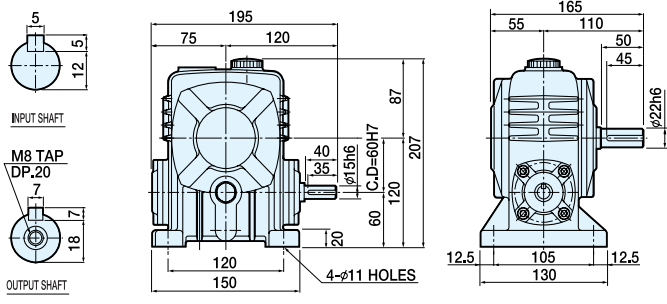
INPUT rpm RATIO	900				600				300			
	INPUT HP	OUTPUT HP	OUTPUT T kgf-m	OUTPUT O.H.L kgf	INPUT HP	OUTPUT HP	OUTPUT T kgf-m	OUTPUT O.H.L kgf	INPUT HP	OUTPUT HP	OUTPUT T kgf-m	OUTPUT O.H.L kgf
1/10	0.89	0.68	5.43	115	0.60	0.45	5.43	115	0.30	0.22	5.43	115
1/15	0.63	0.45	5.43	115	0.43	0.30	5.43	115	0.22	0.15	5.43	115
1/20	0.43	0.31	4.94	115	0.32	0.22	5.43	115	0.17	0.11	5.43	115
1/25	0.39	0.25	5.32	115	0.27	0.19	5.43	115	0.15	0.09	5.43	115
1/30	0.37	0.23	5.43	115	0.25	0.15	5.43	115	0.15	0.07	5.43	115
1/40	0.28	0.17	5.43	115	0.20	0.11	5.43	115	0.11	0.05	5.43	115
1/50	0.24	0.12	5.43	115	0.17	0.09	5.43	115	0.09	0.04	5.43	115
1/60	0.21	0.11	5.34	115	0.15	0.07	5.43	115	0.08	0.03	5.43	115

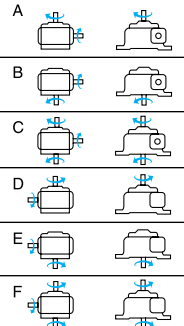
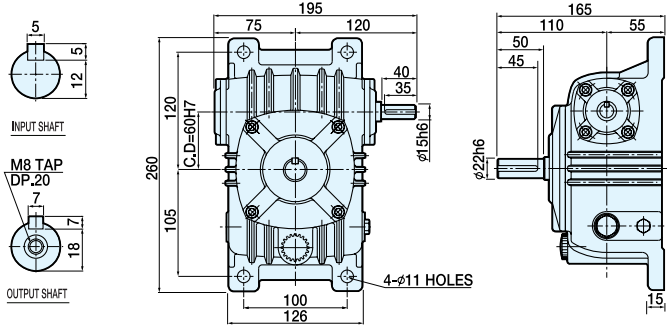
MODEL	축배치 및 회전방향	도면
 <p>WU-60 W ≈ 10kg</p>		
 <p>WB-60 W ≈ 10kg</p>		
 <p>WV-60 W ≈ 10kg</p>		

전동능력표







수치는 1일 8~10시간 연속 운전이고 균일 하중의 수치입니다.

INPUT rpm / RATIO	1800				1500				1200			
	INPUT HP	OUTPUT HP	OUTPUT T kgf-m	OUTPUT O.H.L kgf	INPUT HP	OUTPUT HP	OUTPUT T kgf-m	OUTPUT O.H.L kgf	INPUT HP	OUTPUT HP	OUTPUT T kgf-m	OUTPUT O.H.L kgf
1/10	2.32	1.87	7.44	98	2.08	1.67	7.95	104	1.88	1.47	8.8	110
1/15	1.73	1.32	7.91	116	1.55	1.19	8.46	123	1.36	1.01	9.07	133
1/20	1.21	0.89	7.15	138	1.11	0.80	7.66	146	0.98	0.69	8.31	157
1/25	1.24	0.92	9.10	153	1.12	0.83	9.70	162	0.99	0.71	10.5	174
1/30	1.15	0.75	9.31	151	1.05	0.71	10.0	159	0.92	0.59	10.6	172
1/40	0.83	0.52	8.27	178	0.75	0.47	8.83	189	0.67	0.39	9.49	200
1/50	0.77	0.49	9.70	200	0.71	0.43	10.2	200	0.63	0.37	11.0	200
1/60	0.64	0.39	9.20	200	0.59	0.35	9.70	200	0.51	0.29	10.4	200

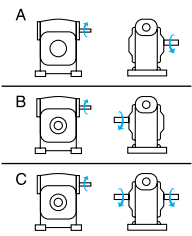
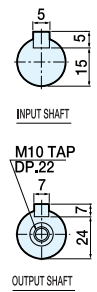
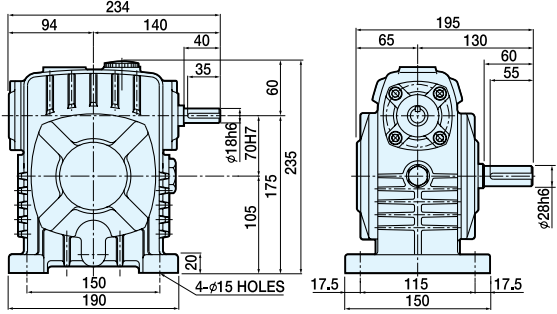
INPUT rpm / RATIO	900				600				300			
	INPUT HP	OUTPUT HP	OUTPUT T kgf-m	OUTPUT O.H.L kgf	INPUT HP	OUTPUT HP	OUTPUT T kgf-m	OUTPUT O.H.L kgf	INPUT HP	OUTPUT HP	OUTPUT T kgf-m	OUTPUT O.H.L kgf
1/10	1.57	1.21	9.68	121	1.23	0.93	11.1	138	0.65	0.48	11.6	175
1/15	1.17	0.85	10.2	145	0.91	0.64	11.5	167	0.48	0.32	11.6	200
1/20	0.83	0.57	9.16	172	0.65	0.43	10.4	198	0.39	0.24	11.6	200
1/25	0.83	0.59	11.5	192	0.48	0.32	11.6	200	0.31	0.19	11.6	200
1/30	0.79	0.48	11.6	189	0.55	0.32	11.6	200	0.29	0.16	11.6	200
1/40	0.59	0.32	10.4	200	0.45	0.24	11.6	200	0.25	0.12	11.6	200
1/50	0.40	0.23	9.22	200	0.31	0.17	10.3	200	0.19	0.11	11.6	200
1/60	0.43	0.24	11.3	200	0.25	0.12	9.52	200	0.15	0.07	11.2	200

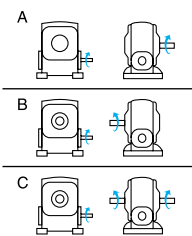
직접구매
WORM REDUCER

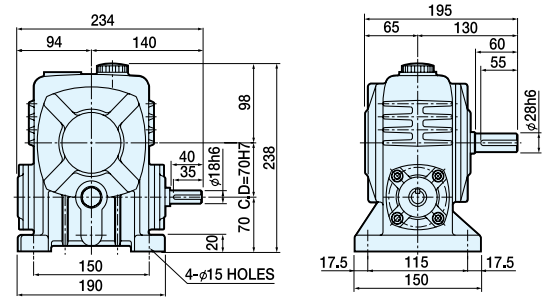
Single Worm Reducer/1단 웜 감속기

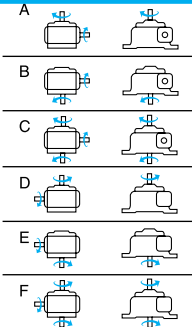
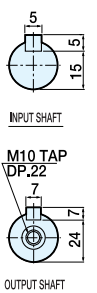
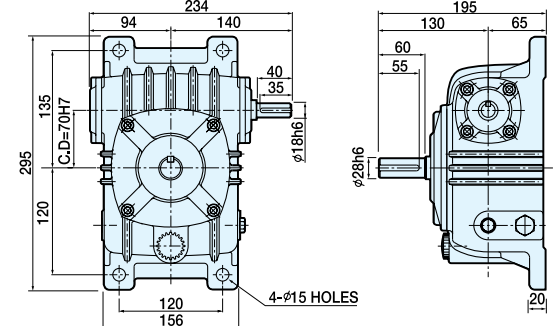



MODEL	축배치 및 회전방향	도	면
 <p>WU-70 W ≈ 15kg</p>			
 <p>WB-70 W ≈ 15kg</p>			
 <p>WV-70 W ≈ 15kg</p>			

전동능력표

수치는 1일 8~10시간 연속 운전이고 균일 하중의 수치입니다.

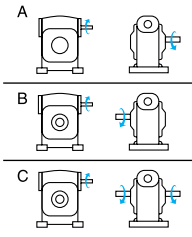
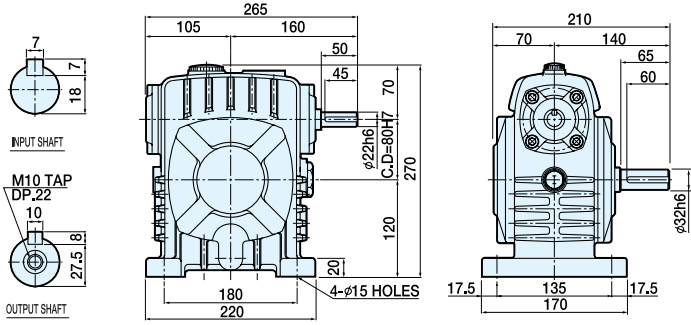
INPUT rpm RATIO	1800				1500				1200			
	INPUT HP	OUTPUT HP	OUTPUT T kgf-m	OUTPUT O.H.L kgf	INPUT HP	OUTPUT HP	OUTPUT T kgf-m	OUTPUT O.H.L kgf	INPUT HP	OUTPUT HP	OUTPUT T kgf-m	OUTPUT O.H.L kgf
1/10	3.47	2.82	11.2	128	3.11	2.51	11.9	136	2.77	2.20	13.1	145
1/15	2.53	1.96	11.7	153	2.29	1.76	12.6	161	2.03	1.52	13.6	174
1/20	1.93	1.47	11.7	178	1.75	1.31	12.5	188	1.55	1.15	13.6	202
1/25	1.79	1.33	13.3	203	1.63	1.19	14.3	211	1.43	1.03	15.3	231
1/30	1.69	1.16	13.8	198	1.55	1.05	15.0	208	1.36	0.89	16.1	225
1/40	1.24	0.83	13.1	233	1.13	0.73	14.0	247	1.01	0.63	15.0	266
1/50	1.12	0.72	14.3	266	1.03	0.64	15.2	282	0.91	0.55	16.3	300
1/60	0.95	0.59	13.9	289	0.87	0.51	14.6	300	0.76	0.43	15.6	300

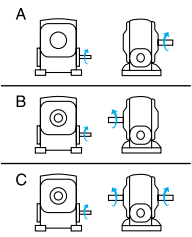
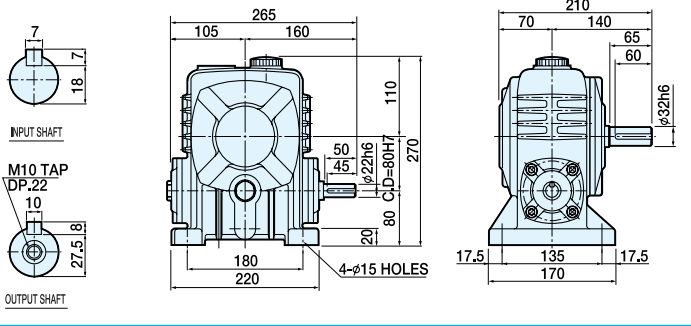
INPUT rpm RATIO	900				600				300			
	INPUT HP	OUTPUT HP	OUTPUT T kgf-m	OUTPUT O.H.L kgf	INPUT HP	OUTPUT HP	OUTPUT T kgf-m	OUTPUT O.H.L kgf	INPUT HP	OUTPUT HP	OUTPUT T kgf-m	OUTPUT O.H.L kgf
1/10	2.33	1.81	14.4	159	1.85	1.41	16.9	180	1.20	0.88	21.1	228
1/15	1.73	1.28	15.2	190	1.33	0.96	17.3	218	0.87	0.59	21.4	277
1/20	1.31	0.95	15.0	222	1.03	0.71	17.1	255	0.65	0.43	20.6	300
1/25	1.21	0.85	16.8	255	0.95	0.64	20.1	284	0.60	0.39	23.8	300
1/30	1.19	0.75	17.7	247	0.92	0.56	20.1	284	0.59	0.33	23.8	300
1/40	0.87	0.51	16.5	293	0.67	0.39	18.6	300	0.43	0.23	21.9	300
1/50	0.77	0.45	17.8	300	0.60	0.33	19.7	300	0.39	0.19	23.2	300
1/60	0.65	0.36	17.0	300	0.51	0.27	18.6	300	0.32	0.15	22.0	300

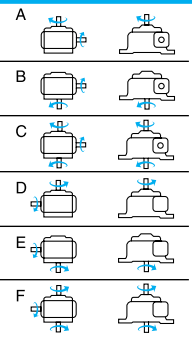
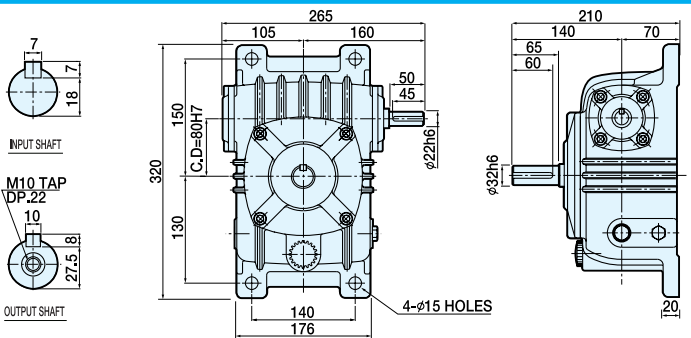
MODEL	축배치 및 회전방향	도면
 <p>WU-80 W ≈ 20kg</p>		
 <p>WB-80 W ≈ 20kg</p>		
 <p>WV-80 W ≈ 20kg</p>		

전동능력표





수치는 1일 8~10시간 연속 운전이고 균일 하중의 수치입니다.

INPUT rpm / RATIO	1800				1500				1200			
	INPUT HP	OUTPUT HP	OUTPUT T kgf-m	OUTPUT O.H.L kgf	INPUT HP	OUTPUT HP	OUTPUT T kgf-m	OUTPUT O.H.L kgf	INPUT HP	OUTPUT HP	OUTPUT T kgf-m	OUTPUT O.H.L kgf
1/10	4.93	4.01	15.9	180	4.43	3.59	17.0	191	3.89	3.12	18.6	204
1/15	3.60	2.79	16.7	215	3.20	2.49	17.8	228	2.83	2.17	19.4	244
1/20	2.53	1.91	15.1	253	2.31	1.71	16.3	267	2.04	1.49	17.8	287
1/25	2.49	1.87	18.5	279	2.25	1.67	19.9	296	1.99	1.44	21.4	318
1/30	2.40	1.67	19.8	277	2.13	1.47	21.1	294	1.91	1.28	22.9	316
1/40	1.71	1.11	17.5	326	1.55	0.99	18.7	347	1.39	0.85	20.4	372
1/50	1.57	1.01	20.1	364	1.43	0.91	21.6	385	1.28	0.77	23.1	400
1/60	1.29	0.79	18.9	400	1.19	0.71	20.4	400	1.05	0.60	21.6	400

INPUT rpm / RATIO	900				600				300			
	INPUT HP	OUTPUT HP	OUTPUT T kgf-m	OUTPUT O.H.L kgf	INPUT HP	OUTPUT HP	OUTPUT T kgf-m	OUTPUT O.H.L kgf	INPUT HP	OUTPUT HP	OUTPUT T kgf-m	OUTPUT O.H.L kgf
1/10	3.31	2.59	20.6	224	2.63	2.03	24.1	254	1.71	1.27	30.1	321
1/15	2.44	1.81	31.7	267	1.91	1.39	24.7	306	1.24	0.85	30.7	388
1/20	1.71	1.23	19.5	316	1.37	0.93	22.4	362	0.89	0.57	27.2	400
1/25	1.65	1.19	23.5	350	1.32	0.91	26.7	400	0.84	0.55	31.9	400
1/30	1.65	1.07	22.2	345	1.31	0.80	28.7	398	0.84	0.47	34.0	400
1/40	1.19	0.69	22.2	400	0.95	0.52	25.0	400	0.63	0.31	29.8	400
1/50	1.09	0.63	25.1	400	0.85	0.47	28.0	400	0.55	0.28	33.0	400
1/60	0.91	0.51	23.7	400	0.71	0.36	26.0	400	0.47	0.21	30.8	400

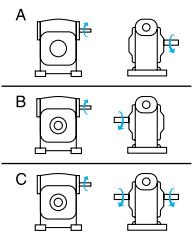
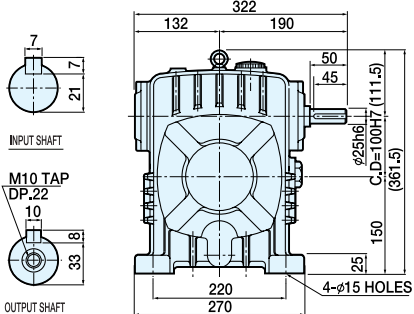
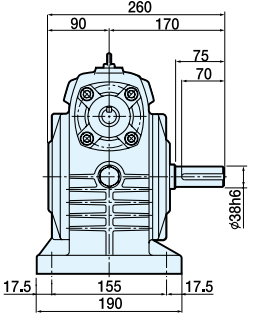
주식회사 삼양
WORM REDUCER

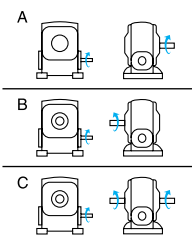
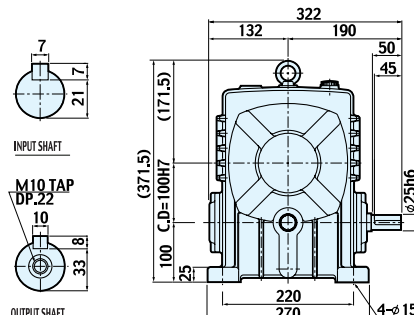
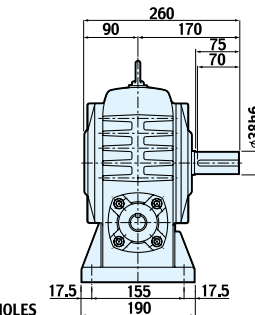
Single Worm Reducer/1단 웜 감속기

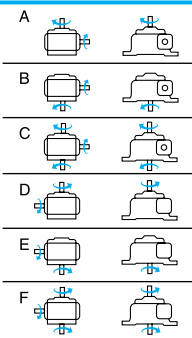
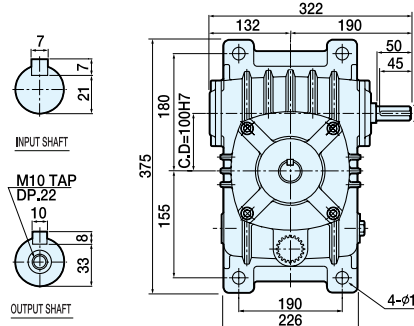
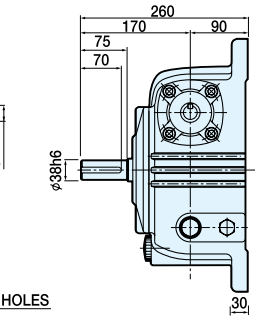



MODEL	축배치 및 회전방향	도	단
 <p>WU-100 W ≈ 40kg</p>			
 <p>WB-100 W ≈ 40kg</p>			
 <p>WV-100 W ≈ 45kg</p>			

전동능력표

수치는 1일 8~10시간 연속 운전이고 균일 하중의 수치입니다.

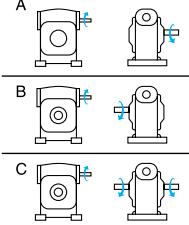
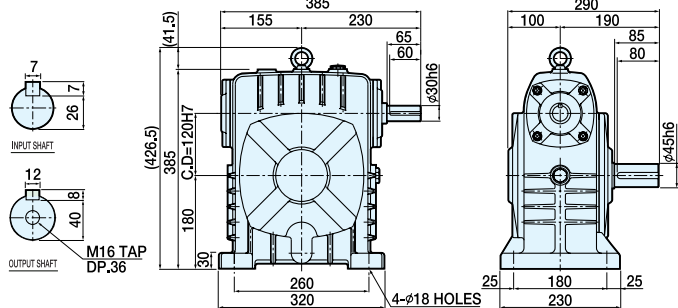
INPUT rpm RATIO	1800				1500				1200			
	INPUT HP	OUTPUT HP	OUTPUT T kgf-m	OUTPUT O.H.L kgf	INPUT HP	OUTPUT HP	OUTPUT T kgf-m	OUTPUT O.H.L kgf	INPUT HP	OUTPUT HP	OUTPUT T kgf-m	OUTPUT O.H.L kgf
1/10	8.73	7.19	28.5	167	7.93	6.47	30.8	177	6.93	5.60	33.4	190
1/15	6.33	5.03	29.9	204	5.67	4.43	31.7	217	5.09	4.00	35.3	230
1/20	5.03	3.93	31.2	239	4.57	3.55	33.8	252	4.03	3.09	36.9	269
1/25	3.95	3.03	30.1	272	3.53	2.67	31.9	289	3.15	2.35	35.0	302
1/30	4.20	3.00	35.8	265	3.81	2.67	38.2	281	3.35	2.31	41.1	302
1/40	3.17	2.20	35.1	316	2.87	1.96	37.4	336	2.55	1.71	40.9	359
1/50	2.39	1.59	31.8	364	2.17	1.43	34.0	386	1.93	1.24	37.0	415
1/60	1.96	1.27	30.4	400	1.79	1.15	32.7	424	1.59	0.97	34.9	458

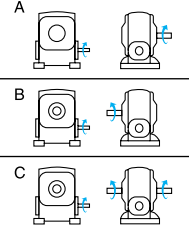
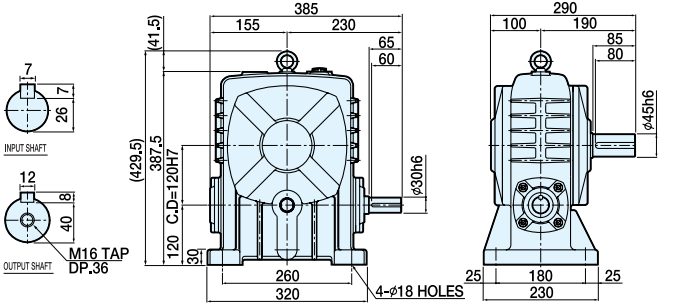
INPUT rpm RATIO	900				600				300			
	INPUT HP	OUTPUT HP	OUTPUT T kgf-m	OUTPUT O.H.L kgf	INPUT HP	OUTPUT HP	OUTPUT T kgf-m	OUTPUT O.H.L kgf	INPUT HP	OUTPUT HP	OUTPUT T kgf-m	OUTPUT O.H.L kgf
1/10	5.87	4.69	37.3	207	4.68	3.65	43.3	235	2.79	2.09	50.0	297
1/15	4.33	3.29	39.3	251	3.39	2.48	44.5	289	1.99	1.39	50.0	365
1/20	3.40	2.53	40.3	297	2.67	1.93	46.2	240	1.52	1.04	50.0	435
1/25	2.67	1.92	38.2	341	2.09	1.47	43.9	390	1.27	0.83	50.0	509
1/30	2.89	1.92	46.0	330	2.23	1.39	50.0	382	1.22	0.69	50.0	538
1/40	2.03	1.28	46.0	397	1.17	1.04	50.0	458	0.92	0.52	50.0	623
1/50	1.67	1.05	40.2	458	1.29	0.75	44.7	528	0.79	0.41	50.0	650
1/60	1.37	0.79	38.1	504	1.05	0.59	42.0	583	0.68	0.35	49.8	650

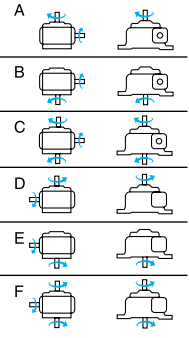
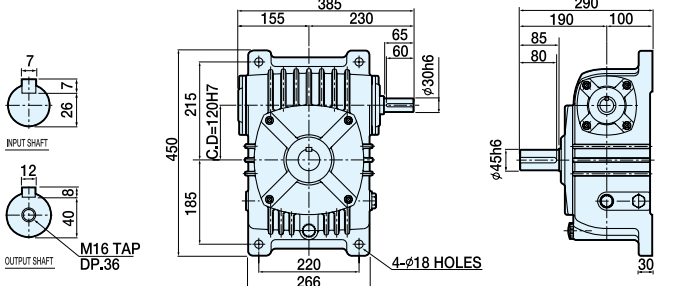
MODEL	축배치 및 회전방향	도면
 <p>WU-120 W ≈ 65kg</p>		
 <p>WB-120 W ≈ 65kg</p>		
 <p>WV-120 W ≈ 70kg</p>		

김속기
WORM REDUCER





전동능력표

수치는 1일 8~10시간 연속 운전이고 균일 하중의 수치입니다.

INPUT rpm RATIO	1800				1500				1200			
	INPUT HP	OUTPUT HP	OUTPUT T kgf-m	OUTPUT O.H.L kgf	INPUT HP	OUTPUT HP	OUTPUT T kgf-m	OUTPUT O.H.L kgf	INPUT HP	OUTPUT HP	OUTPUT T kgf-m	OUTPUT O.H.L kgf
1/10	13.8	11.4	45.7	177	12.6	10.4	49.6	184	11.0	9.03	53.8	198
1/15	10.0	8.05	48.0	218	9.03	7.15	51.2	231	8.08	6.32	56.5	244
1/20	7.16	5.55	44.0	270	6.49	4.97	47.4	285	5.72	4.31	51.3	306
1/25	6.67	5.21	51.8	294	5.93	4.59	54.8	313	5.28	4.05	60.4	333
1/30	6.67	4.83	57.5	285	6.00	4.28	61.3	302	5.31	3.71	66.3	325
1/40	4.68	3.19	50.7	357	4.19	2.81	53.6	380	3.77	2.45	58.5	407
1/50	3.93	2.75	54.5	404	3.55	2.43	58.0	429	3.15	2.12	63.4	459
1/60	3.15	2.04	48.9	453	2.84	1.81	51.9	481	2.52	1.56	56.2	518

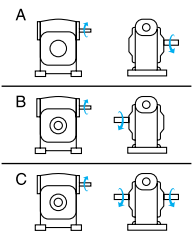
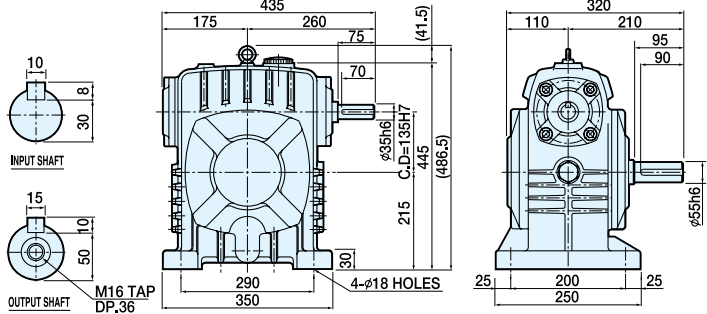
INPUT rpm RATIO	900				600				300			
	INPUT HP	OUTPUT HP	OUTPUT T kgf-m	OUTPUT O.H.L kgf	INPUT HP	OUTPUT HP	OUTPUT T kgf-m	OUTPUT O.H.L kgf	INPUT HP	OUTPUT HP	OUTPUT T kgf-m	OUTPUT O.H.L kgf
1/10	9.39	7.55	60.1	214	7.47	5.87	69.9	241	4.64	3.51	84.0	305
1/15	6.83	5.27	62.8	267	5.39	4.01	71.9	305	3.31	2.35	84.0	386
1/20	4.85	3.59	57.0	335	3.87	2.75	65.4	383	2.53	1.69	80.7	488
1/25	4.45	3.31	65.9	368	3.51	2.53	75.7	420	2.04	1.40	84.0	545
1/30	4.55	3.09	73.9	354	3.65	2.35	83.9	408	1.97	1.17	84.0	531
1/40	3.24	2.03	64.8	446	2.63	1.53	73.3	514	1.64	0.88	84.0	665
1/50	2.69	1.72	68.7	508	2.09	1.28	76.5	588	1.24	0.71	84.0	778
1/60	2.17	1.28	61.3	571	1.71	0.95	67.5	662	1.12	0.56	81.1	846

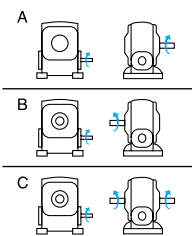
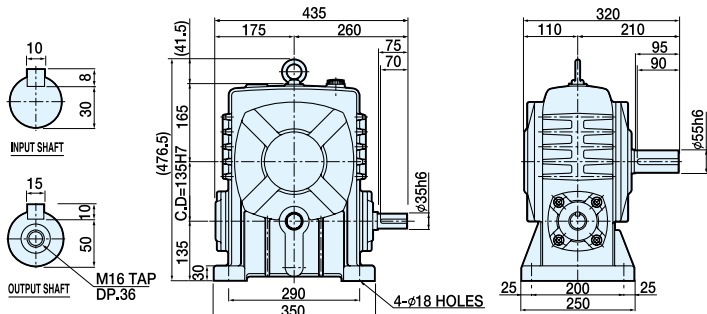
Single Worm Reducer/1단 웜 감속기

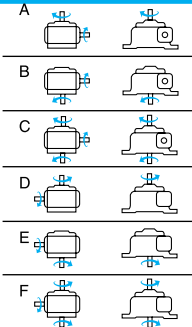
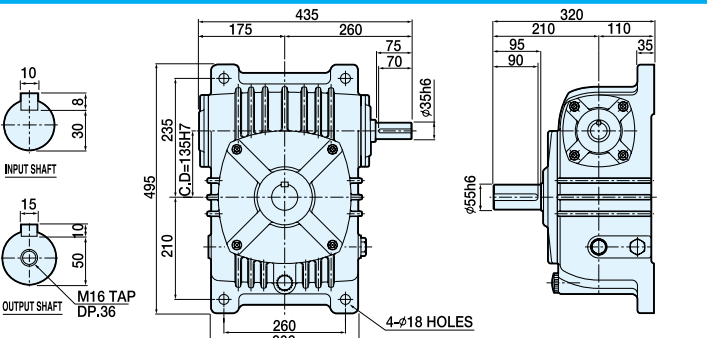



MODEL	축배치 및 회전방향	도면
 <p>WU-135 W ≈ 90 kg</p>		
 <p>WB-135 W ≈ 90 kg</p>		
 <p>WV-135 W ≈ 95 kg</p>		

전동능력표

수치는 1일 8~10시간 연속 운전이고 균일 하중의 수치입니다.

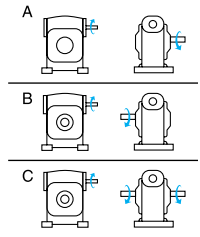
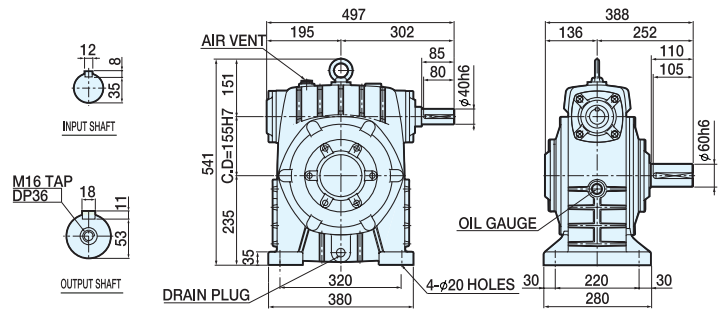
INPUT rpm RATIO	1800				1500				1200			
	INPUT HP	OUTPUT HP	OUTPUT T kgf-m	OUTPUT O.H.L kgf	INPUT HP	OUTPUT HP	OUTPUT T kgf-m	OUTPUT O.H.L kgf	INPUT HP	OUTPUT HP	OUTPUT T kgf-m	OUTPUT O.H.L kgf
1/10	19.7	16.5	66.0	304	18.0	15.0	71.7	319	15.8	13.0	77.7	342
1/15	14.6	11.9	71.4	362	13.1	10.6	76.1	384	11.8	9.39	84.0	407
1/20	11.3	9.11	72.5	426	10.3	8.19	78.2	449	8.97	7.03	83.9	484
1/25	9.04	7.12	70.8	483	8.08	6.31	75.2	514	7.11	5.48	81.7	551
1/30	9.68	7.21	86.0	468	8.71	6.40	91.7	496	7.71	5.53	99.1	533
1/40	6.99	5.08	80.8	566	6.37	4.55	86.8	599	5.60	3.92	93.6	645
1/50	5.28	3.73	74.2	650	4.76	3.29	78.7	691	4.23	2.87	85.8	742
1/60	4.15	2.80	67.0	724	3.75	2.48	71.2	769	3.31	2.15	77.0	827

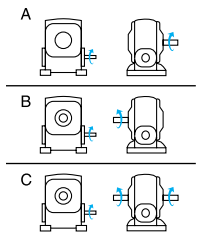
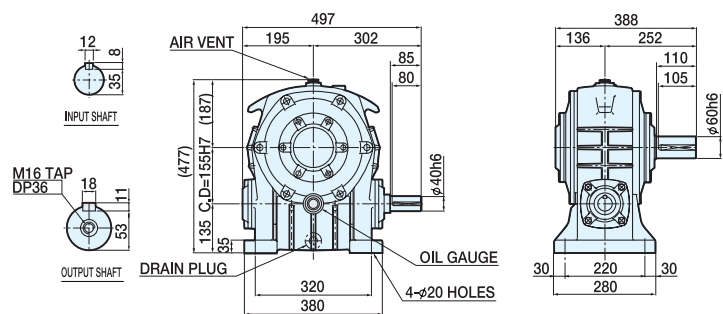
INPUT rpm RATIO	900				600				300			
	INPUT HP	OUTPUT HP	OUTPUT T kgf-m	OUTPUT O.H.L kgf	INPUT HP	OUTPUT HP	OUTPUT T kgf-m	OUTPUT O.H.L kgf	INPUT HP	OUTPUT HP	OUTPUT T kgf-m	OUTPUT O.H.L kgf
1/10	13.3	10.9	86.8	372	10.6	8.46	101	42.1	6.87	5.30	126	533
1/15	9.95	7.83	93.3	445	7.83	5.96	106	510	5.11	3.73	133	644
1/20	7.69	5.92	94.3	528	6.05	4.51	107	605	3.88	2.76	131	772
1/25	6.04	4.55	90.5	605	4.75	3.46	103	693	3.00	2.08	124	890
1/30	6.59	4.63	110	583	5.24	3.50	125	670	3.13	1.95	140	866
1/40	4.80	3.27	104	707	3.81	2.45	117	814	2.43	1.45	138	1051
1/50	3.60	2.35	93.6	819	2.83	1.75	104	944	1.83	1.04	124	1200
1/60	2.84	1.76	84.1	912	2.21	1.29	92.6	1053	1.45	0.77	111	1200

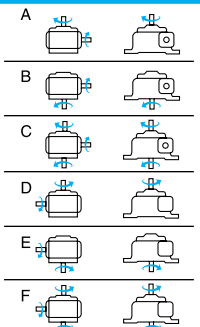
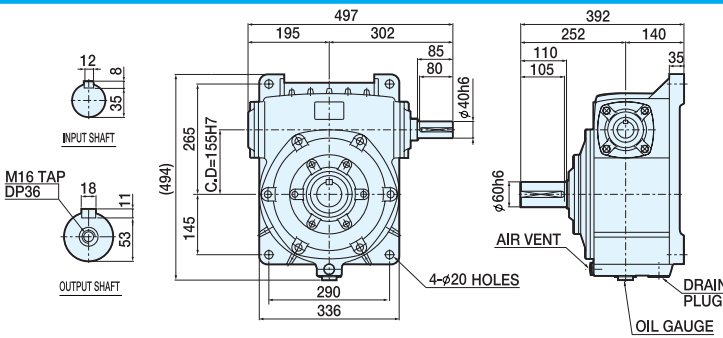
MODEL	축배치 및 회전방향	도면
 <p>WU-155 W ≈ 115 kg</p>		
 <p>WB-155 W ≈ 115 kg</p>		
 <p>WV-155 W ≈ 115 kg</p>		





전동능력표

수치는 1일 8~10시간 연속 운전이고 균일 하중의 수치입니다.

INPUT rpm / RATIO	1800				1500				1200			
	INPUT HP	OUTPUT HP	OUTPUT T kgf-m	OUTPUT O.H.L kgf	INPUT HP	OUTPUT HP	OUTPUT T kgf-m	OUTPUT O.H.L kgf	INPUT HP	OUTPUT HP	OUTPUT T kgf-m	OUTPUT O.H.L kgf
1/10	32.9	27.3	105	1500	29.8	24.6	114	1500	26.4	21.7	125	1500
1/15	22.9	18.5	106	1500	20.5	16.5	114	1500	18.1	14.4	124	1500
1/20	14.9	11.8	94.5	1500	13.5	10.6	102	1500	11.9	9.29	110	1500
1/25	12.0	9.41	93.6	1500	10.8	8.42	100	1500	9.54	7.28	108	1500
1/30	13.3	9.78	112	1500	12.1	8.82	122	1500	10.4	7.55	130	1500
1/40	9.32	6.66	106	1500	8.26	5.86	112	1500	7.40	5.10	122	1500
1/50	7.13	4.97	98.9	1500	6.42	4.40	105	1500	5.76	3.84	114	1500
1/60	5.85	3.98	95.3	1500	5.37	3.57	102	1500	4.72	3.85	109	1500

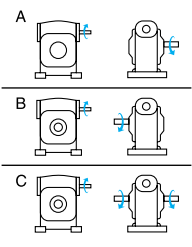
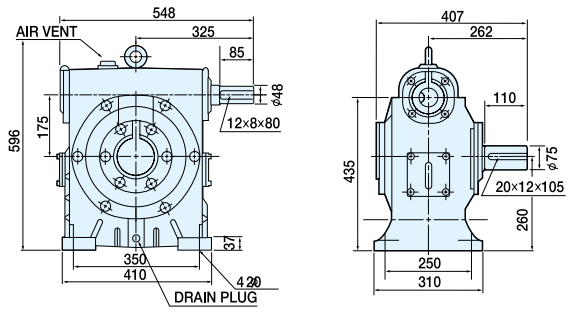
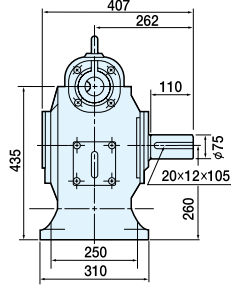
INPUT rpm / RATIO	900				600				300			
	INPUT HP	OUTPUT HP	OUTPUT T kgf-m	OUTPUT O.H.L kgf	INPUT HP	OUTPUT HP	OUTPUT T kgf-m	OUTPUT O.H.L kgf	INPUT HP	OUTPUT HP	OUTPUT T kgf-m	OUTPUT O.H.L kgf
1/10	22.2	18.1	139	1500	17.8	14.3	165	1500	11.7	8.98	207	1500
1/15	15.4	12.0	139	1500	12.1	9.30	161	1500	8.06	5.84	202	1500
1/20	10.0	7.70	122	1500	8.01	5.94	141	1500	5.18	3.65	174	1500
1/25	8.05	6.04	120	1500	6.38	4.61	137	1500	4.09	2.80	167	1500
1/30	9.08	6.32	146	1500	7.24	4.86	168	1500	4.77	2.92	202	1500
1/40	6.28	4.22	134	1500	5.02	3.18	152	1500	3.25	1.90	182	1500
1/50	4.89	3.17	126	1500	3.90	2.37	141	1500	2.53	1.41	168	1500
1/60	3.97	2.50	118	1500	3.20	1.86	133	1500	2.10	1.12	160	1500

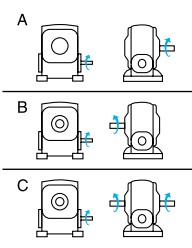
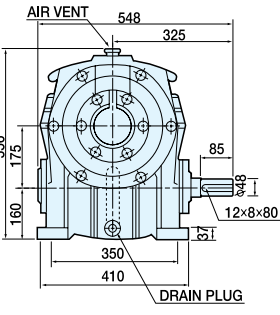
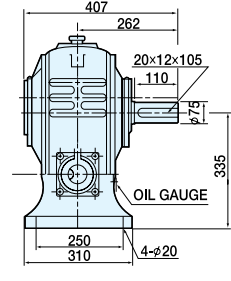
Single Worm Reducer/1단 웜 감속기

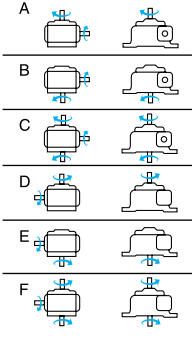
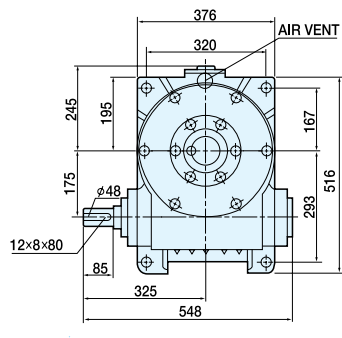
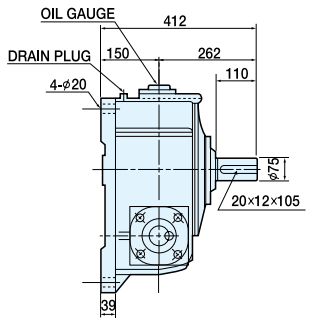
MODEL	축배치 및 회전방향	도면	
 <p>WU-175</p>			
 <p>WB-175</p>			
 <p>WV-175</p>			

전동능력표

수치는 1일 8~10시간 연속 운전이고 균일 하중의 수치입니다.

INPUT rpm RATIO	1800				1500				1200			
	INPUT HP	OUTPUT HP	OUTPUT T kgf-m	OUTPUT O.H.L kgf	INPUT HP	OUTPUT HP	OUTPUT T kgf-m	OUTPUT O.H.L kgf	INPUT HP	OUTPUT HP	OUTPUT T kgf-m	OUTPUT O.H.L kgf
1/10	46.8	39.1	150	1770	42.5	35.4	163	1800	37.7	31.3	180	1800
1/15	33.0	26.7	154	1800	29.6	27.9	165	1800	25.9	20.8	180	1800
1/20	22.8	18.2	141	1800	20.4	16.2	151	1800	18.0	14.2	165	1800
1/25	16.3	12.7	126	1800	14.6	11.4	136	1800	12.8	9.89	147	1800
1/30	19.0	14.1	163	1800	17.2	12.7	176	1800	15.0	11.0	190	1800
1/40	13.2	9.60	149	1800	11.9	8.58	159	1800	10.4	7.36	171	1800
1/50	9.78	6.81	135	1800	8.74	6.03	144	1800	7.98	5.37	160	1800
1/60	8.23	5.74	132	1800	7.74	5.31	147	1800	6.62	4.41	152	1800

INPUT rpm RATIO	900				600				300			
	INPUT HP	OUTPUT HP	OUTPUT T kgf-m	OUTPUT O.H.L kgf	INPUT HP	OUTPUT HP	OUTPUT T kgf-m	OUTPUT O.H.L kgf	INPUT HP	OUTPUT HP	OUTPUT T kgf-m	OUTPUT O.H.L kgf
1/10	31.7	26.0	200	1800	25.2	20.4	235	1800	16.6	12.9	297	1800
1/15	22.1	17.5	202	1800	17.3	13.4	233	1800	11.4	8.44	292	1800
1/20	15.2	11.7	182	1800	12.1	9.15	212	1800	7.87	5.62	261	1800
1/25	10.8	8.18	162	1800	8.66	6.31	188	1800	5.57	3.82	228	1800
1/30	12.9	9.20	212	1800	10.2	7.04	243	1800	6.73	4.23	293	1800
1/40	8.98	6.12	190	1800	7.10	4.65	216	1800	4.69	2.80	261	1800
1/50	6.64	4.32	171	1800	5.28	3.25	194	1800	3.46	1.94	231	1800
1/60	5.56	3.60	166	1800	4.45	2.70	187	1800	2.90	1.62	224	1800

#200 이상의 모델에는 냉각팬은 주문사양입니다

MODEL 축배치 및 회전방향 도 면



WB-200

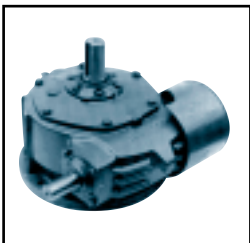
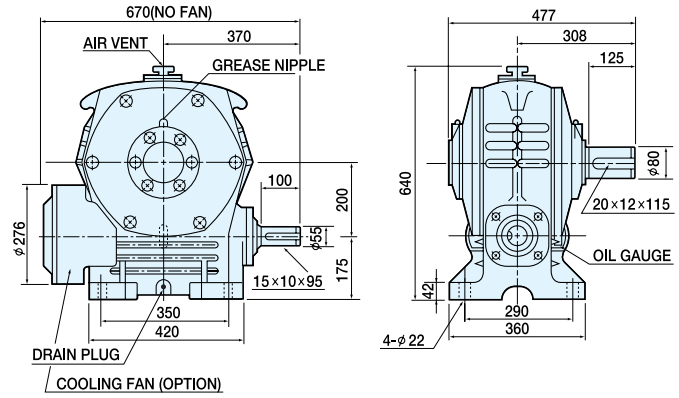
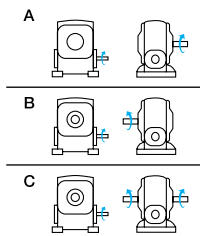

WV-200

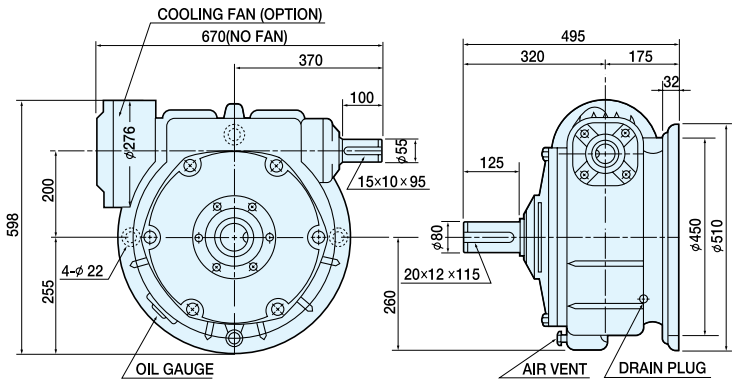
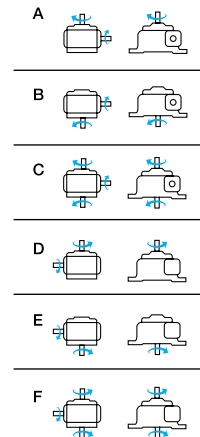

전동능력표

수치는 1일 8~10시간 연속 운전이고 균일 하중의 수치입니다.

INPUT rpm RATIO	1800				1500				1200			
	INPUT HP	OUTPUT HP	OUTPUT T kgf-m	OUTPUT O.H.L kgf	INPUT HP	OUTPUT HP	OUTPUT T kgf-m	OUTPUT O.H.L kgf	INPUT HP	OUTPUT HP	OUTPUT T kgf-m	OUTPUT O.H.L kgf
1/10	52.6	44.0	181	1750	47.7	39.9	196	1840	41.8	34.8	215	1950
1/15	39.5	32.1	198	1990	35.4	28.7	212	2090	30.9	25.0	231	2200
1/20	30.2	24.3	193	2200	27.0	21.6	206	2200	23.8	18.9	226	2200
1/25	23.3	18.5	184	2200	21.0	16.6	198	2200	18.4	14.3	214	2200
1/30	25.1	18.8	232	2200	22.6	16.8	249	2200	19.8	14.6	270	2200
1/40	18.2	13.3	213	2200	16.5	12.0	230	2200	14.3	10.3	247	2200
1/50	13.8	9.84	195	2200	12.3	8.68	207	2200	11.2	7.76	231	2200
1/60	11.5	8.01	188	2200	10.3	7.11	200	2200	9.64	6.49	228	2200

INPUT rpm RATIO	900				600				300			
	INPUT HP	OUTPUT HP	OUTPUT T kgf-m	OUTPUT O.H.L kgf	INPUT HP	OUTPUT HP	OUTPUT T kgf-m	OUTPUT O.H.L kgf	INPUT HP	OUTPUT HP	OUTPUT T kgf-m	OUTPUT O.H.L kgf
1/10	35.6	29.3	241	2120	28.0	22.8	281	2200	18.5	14.4	356	2200
1/15	26.3	21.0	259	2200	20.6	16.1	298	2200	13.6	10.0	373	2200
1/20	20.1	15.7	250	2200	15.9	12.2	291	2200	10.3	7.48	357	2200
1/25	15.5	11.9	237	2200	12.4	9.24	275	2200	7.97	5.59	333	2200
1/30	16.9	12.1	300	2200	13.3	9.32	345	2200	8.78	5.60	414	2200
1/40	12.3	8.62	274	2200	9.56	6.43	307	2200	6.44	3.94	376	2200
1/50	9.29	6.21	247	2200	7.33	4.69	280	2200	4.83	2.80	334	2200
1/60	7.76	5.05	237	2200	6.12	3.77	265	2200	4.03	2.26	318	2200

Single Worm Reducer/1단 웜 감속기

MODEL 축배치 및 회전방향 도면



WB-225

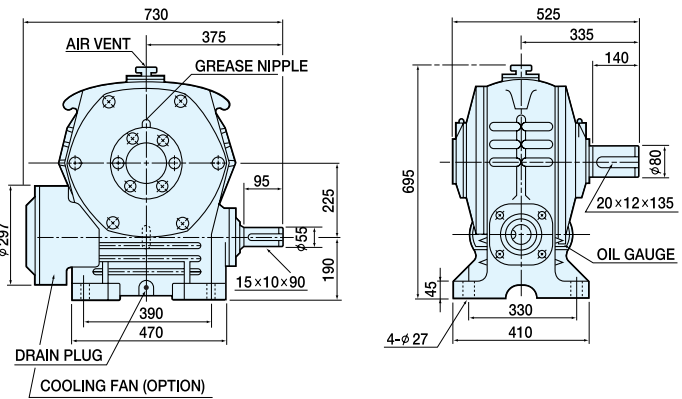
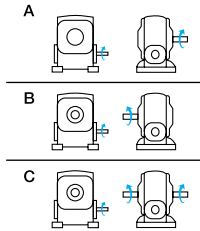

WV-225

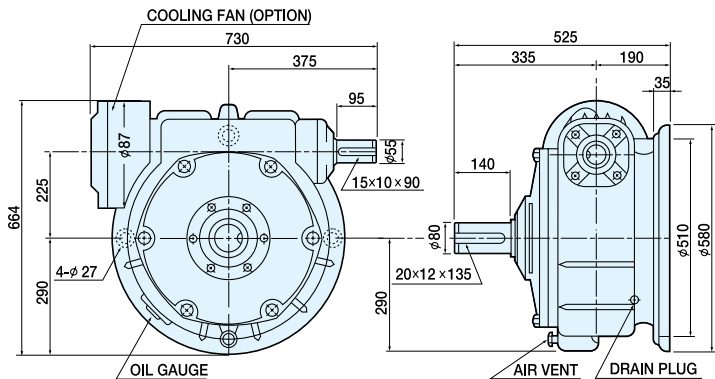
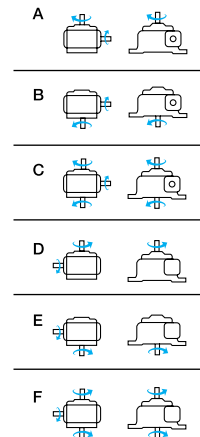

전동능력표

수치는 1일 8~10시간 연속 운전이고 균일 하중의 수치입니다.

INPUT rpm RATIO	1800				1500				1200			
	INPUT HP	OUTPUT HP	OUTPUT T kgf-m	OUTPUT O.H.L kgf	INPUT HP	OUTPUT HP	OUTPUT T kgf-m	OUTPUT O.H.L kgf	INPUT HP	OUTPUT HP	OUTPUT T kgf-m	OUTPUT O.H.L kgf
1/10	71.2	60.2	239	2150	64.6	54.5	260	2260	56.7	47.7	284	2400
1/15	56.8	46.9	280	2410	50.9	41.9	300	2500	44.4	36.4	326	2500
1/20	43.4	35.2	280	2500	38.7	31.2	298	2500	34.1	27.4	327	2500
1/25	33.4	26.8	267	2500	30.1	24.1	287	2500	26.3	20.8	311	2500
1/30	37.3	28.7	342	2500	33.5	25.6	367	2500	29.3	22.3	399	2500
1/40	25.9	19.3	307	2500	23.6	17.4	333	2500	20.4	14.9	357	2500
1/50	19.4	14.2	282	2500	17.2	12.5	299	2500	15.6	11.1	334	2500
1/60	16.0	11.3	262	2500	14.2	10.0	278	2500	13.2	9.19	318	2500

INPUT rpm RATIO	900				600				300			
	INPUT HP	OUTPUT HP	OUTPUT T kgf-m	OUTPUT O.H.L kgf	INPUT HP	OUTPUT HP	OUTPUT T kgf-m	OUTPUT O.H.L kgf	INPUT HP	OUTPUT HP	OUTPUT T kgf-m	OUTPUT O.H.L kgf
1/10	48.1	40.1	319	2500	37.9	31.2	372	2500	24.9	19.8	473	2500
1/15	37.8	30.6	365	2500	29.5	23.5	422	2500	19.3	14.7	527	2500
1/20	28.8	22.8	363	2500	22.7	17.6	421	2500	14.7	10.8	518	2500
1/25	22.2	17.3	344	2500	17.6	13.4	400	2500	11.2	8.12	484	2500
1/30	24.9	18.5	442	2500	19.6	14.2	508	2500	12.7	8.54	611	2500
1/40	17.6	12.5	399	2500	13.6	9.36	447	2500	9.09	5.72	546	2500
1/50	12.9	8.96	356	2500	10.1	6.77	404	2500	6.65	4.04	482	2500
1/60	10.6	7.15	330	2500	8.37	5.35	370	2500	5.51	3.20	443	2500

MODEL 축배치 및 회전방향 도면



WB-250

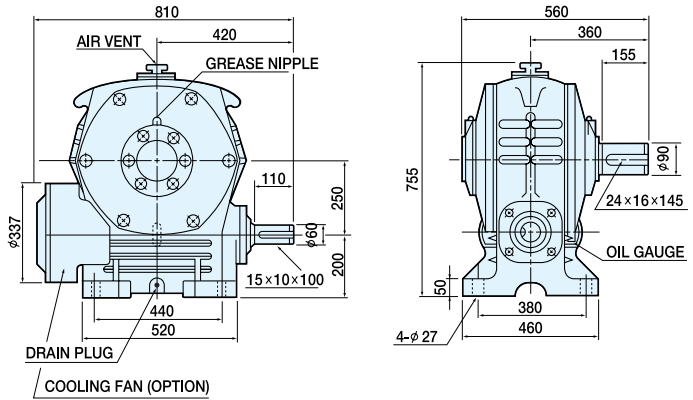
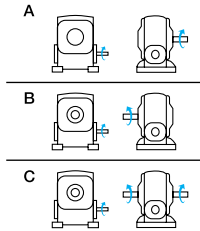

COOLING FAN (OPTION)



WV-250

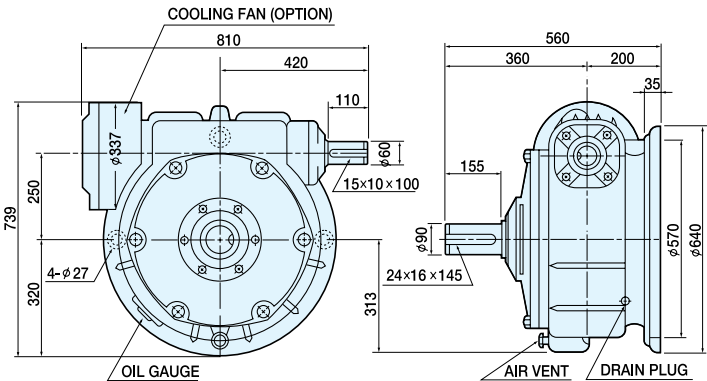
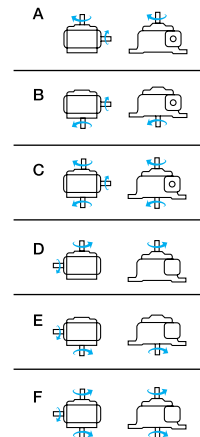

전동능력표

수치는 1일 8~10시간 연속 운전이고 균일 하중의 수치입니다.

INPUT rpm RATIO	1800				1500				1200			
	INPUT HP	OUTPUT HP	OUTPUT T kgf-m	OUTPUT O.H.L kgf	INPUT HP	OUTPUT HP	OUTPUT T kgf-m	OUTPUT O.H.L kgf	INPUT HP	OUTPUT HP	OUTPUT T kgf-m	OUTPUT O.H.L kgf
1/10	96.6	81.3	323	2700	88.3	74.2	354	2700	78.4	65.7	392	2700
1/15	72.3	59.3	354	2700	66.4	54.3	389	2700	57.9	47.2	423	2700
1/20	55.3	45.0	367	2700	49.2	39.9	391	2700	43.3	35.0	428	2700
1/25	41.0	33.1	342	2700	36.9	29.6	367	2700	32.1	25.6	397	2700
1/30	47.2	35.8	427	2700	42.2	31.9	457	2700	37.1	27.9	499	2700
1/40	32.9	24.6	401	2700	29.8	22.2	435	2700	25.9	19.1	468	2700
1/50	23.7	17.3	359	2700	21.2	15.4	383	2700	18.7	13.5	418	2700
1/60	20.2	14.6	350	2700	18.0	12.9	371	2700	16.8	11.9	426	2700

INPUT rpm RATIO	900				600				300			
	INPUT HP	OUTPUT HP	OUTPUT T kgf-m	OUTPUT O.H.L kgf	INPUT HP	OUTPUT HP	OUTPUT T kgf-m	OUTPUT O.H.L kgf	INPUT HP	OUTPUT HP	OUTPUT T kgf-m	OUTPUT O.H.L kgf
1/10	65.5	54.7	435	2700	51.8	42.6	508	2700	34.2	27.1	648	2700
1/15	49.0	39.7	474	2700	38.3	30.3	544	2700	25.3	19.2	689	2700
1/20	36.4	29.0	473	2700	28.7	22.4	549	2700	18.6	13.8	678	2700
1/25	27.3	21.3	441	2700	21.5	16.5	513	2700	13.7	9.96	618	2700
1/30	31.0	23.0	551	2700	24.7	17.6	633	2700	16.3	10.8	774	2700
1/40	22.8	16.4	537	2700	17.2	11.9	587	2700	11.4	7.30	715	2700
1/50	15.8	11.0	458	2700	12.2	8.23	511	2700	8.12	4.97	617	2700
1/60	13.4	9.21	439	2700	10.5	6.88	4.93	2700	6.91	4.13	591	2700

Single Worm Reducer/1단 웜 감속기

MODEL 축배치 및 회전방향 도면



WB-300

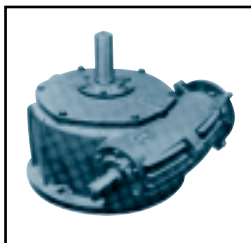
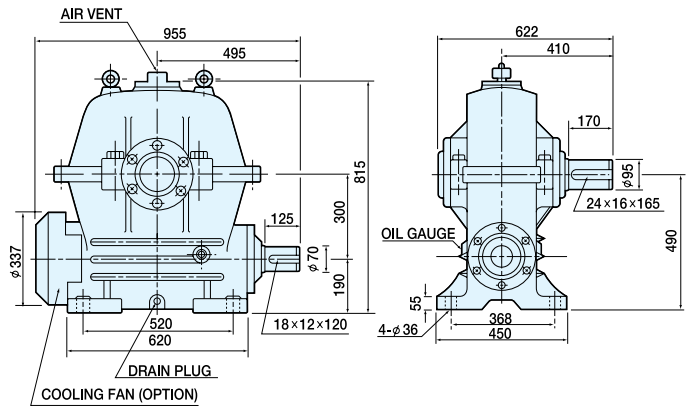
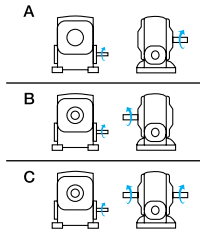

WV-300

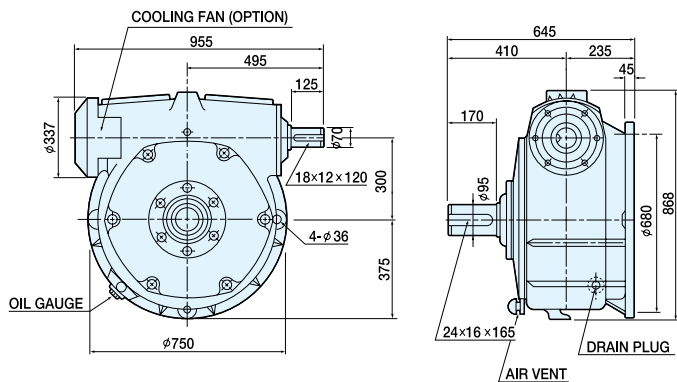
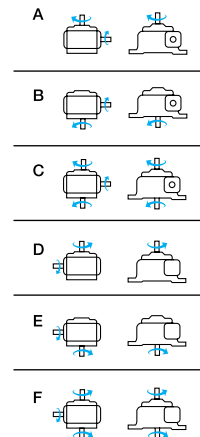

전동능력표

수치는 1일 8~10시간 연속 운전이고 균일 하중의 수치입니다.

INPUT rpm RATIO	1800				1500				1200			
	INPUT HP	OUTPUT HP	OUTPUT T kgf-m	OUTPUT O.H.L kgf	INPUT HP	OUTPUT HP	OUTPUT T kgf-m	OUTPUT O.H.L kgf	INPUT HP	OUTPUT HP	OUTPUT T kgf-m	OUTPUT O.H.L kgf
1/10	137	116	479	2360	126	106	527	2470	111	94.3	581	2610
1/15	116	96.8	597	2600	107	88.9	658	2710	93.2	77.2	714	2880
1/20	93.8	77.1	614	2860	84.4	69.3	662	3000	73.5	60.1	718	3200
1/25	70.1	56.6	563	3100	62.9	50.7	605	3320	55.6	44.6	665	3510
1/30	80.1	62.3	769	3160	71.5	55.5	822	3330	62.8	48.6	899	3530
1/40	57.0	43.5	692	3600	50.8	38.7	740	3790	44.6	33.7	805	3800
1/50	40.6	29.9	595	3800	36.3	26.7	637	3800	31.8	23.1	691	3800
1/60	32.3	23.5	570	3800	29.1	21.0	612	3800	25.3	18.1	658	3800

INPUT rpm RATIO	900				600				300			
	INPUT HP	OUTPUT HP	OUTPUT T kgf-m	OUTPUT O.H.L kgf	INPUT HP	OUTPUT HP	OUTPUT T kgf-m	OUTPUT O.H.L kgf	INPUT HP	OUTPUT HP	OUTPUT T kgf-m	OUTPUT O.H.L kgf
1/10	93.3	78.7	647	2830	73.5	61.1	753	3170	48.3	38.9	961	3800
1/15	78.8	64.9	800	3120	61.4	49.6	919	3500	40.4	31.4	1160	3800
1/20	61.6	49.9	795	3470	48.5	38.5	920	3800	31.7	24.1	1150	3800
1/25	46.1	36.6	729	3810	36.5	28.3	845	3800	23.7	17.4	1030	3800
1/30	52.4	40.2	992	3800	41.5	30.7	1130	3800	23.3	16.2	1200	3800
1/40	39.3	29.2	931	3800	29.7	21.3	1010	3800	18.8	12.5	1200	3800
1/50	27.4	19.6	781	3800	21.1	14.4	863	3800	13.9	8.75	1040	3800
1/60	21.5	15.0	728	3800	16.6	11.1	811	3800	11.0	6.71	977	3800

MODEL 축배치 및 회전방향 도 면



WB-350

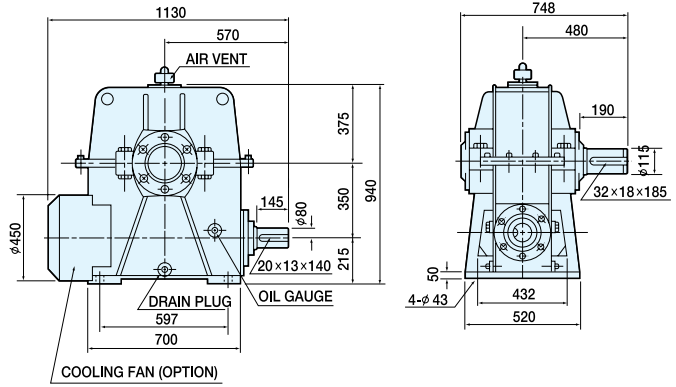
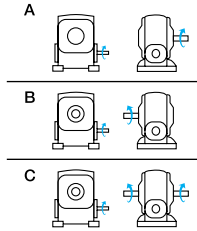

WV-350

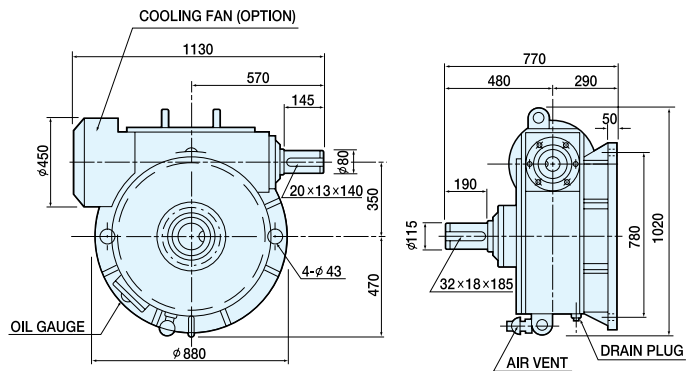
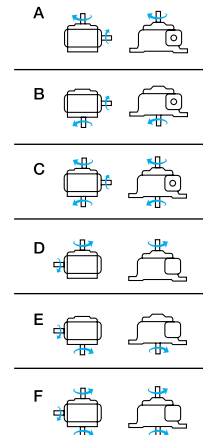

전동능력표

수치는 1일 8~10시간 연속 운전이고 균일 하중의 수치입니다.

INPUT rpm RATIO	1800				1500				1200			
	INPUT HP	OUTPUT HP	OUTPUT T kgf-m	OUTPUT O.H.L kgf	INPUT HP	OUTPUT HP	OUTPUT T kgf-m	OUTPUT O.H.L kgf	INPUT HP	OUTPUT HP	OUTPUT T kgf-m	OUTPUT O.H.L kgf
1/10	-	-	-	-	183	155	769	3200	164	139	859	3380
1/15	-	-	-	-	157	130	968	3500	140	116	1070	3692
1/20	147	122	946	3620	135	112	1040	3770	117	96.4	1120	4020
1/25	112	92.3	918	4040	100	82.2	981	4250	88.8	72.4	1080	4510
1/30	-	-	-	-	91.4	78.4	1240	4260	79.7	61.2	1340	4530
1/40	87.9	67.7	1050	4590	78.6	60.4	1120	4830	69.5	53.2	1230	5100
1/50	64.5	48.9	974	5100	57.8	43.7	1040	5100	50.5	37.9	1130	5100
1/60	49.4	36.4	869	5100	44.2	32.4	930	5100	38.7	28.1	1000	5100

INPUT rpm RATIO	900				600				300			
	INPUT HP	OUTPUT HP	OUTPUT T kgf-m	OUTPUT O.H.L kgf	INPUT HP	OUTPUT HP	OUTPUT T kgf-m	OUTPUT O.H.L kgf	INPUT HP	OUTPUT HP	OUTPUT T kgf-m	OUTPUT O.H.L kgf
1/10	137	116	955	3660	108	90.7	1110	4080	71.1	57.8	1420	4970
1/15	117	97.5	1200	3990	92.3	75.1	1390	4470	60.2	47.3	1750	5100
1/20	99.4	81.4	1260	4340	77.5	62.2	1440	4870	50.1	38.6	1800	5100
1/25	73.5	59.4	1180	4910	58.0	45.9	1370	5100	37.3	28.1	1680	5100
1/30	78.8	60.8	1500	4900	62.4	46.9	1730	5100	34.3	24.3	1800	5100
1/40	58.0	43.9	1360	5100	45.6	33.4	1550	5100	28.2	19.3	1800	5100
1/50	43.6	32.2	1280	5100	33.2	23.6	1410	5100	21.7	14.3	1710	5100
1/60	32.5	23.2	1110	5100	25.3	17.3	1240	5100	16.8	10.5	1500	5100

Single Worm Reducer/1단 웜 감속기

MODEL 축배치 및 회전방향 도 면



WB-400

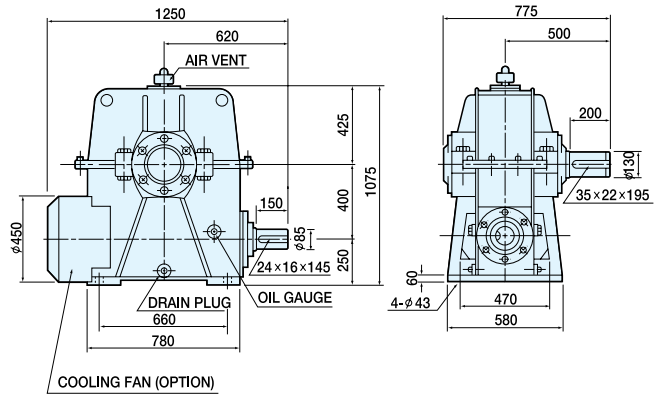
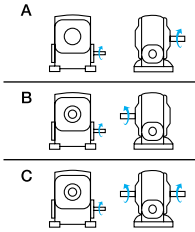

WV-400

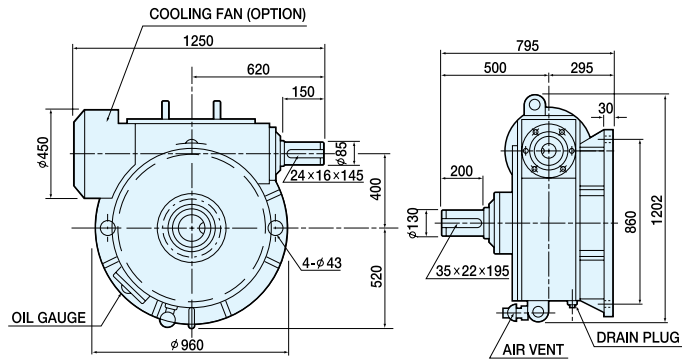
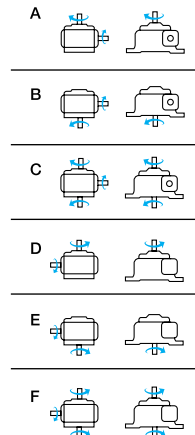

전동능력표

수치는 1일 8~10시간 연속 운전이고 균일 하중의 수치입니다.

INPUT rpm RATIO	1800				1500				1200			
	INPUT HP	OUTPUT HP	OUTPUT T kgf-m	OUTPUT O.H.L kgf	INPUT HP	OUTPUT HP	OUTPUT T kgf-m	OUTPUT O.H.L kgf	INPUT HP	OUTPUT HP	OUTPUT T kgf-m	OUTPUT O.H.L kgf
1/10	-	-	-	-	266	266	1110	3790	238	202	1240	4000
1/15	-	-	-	-	218	181	1340	4200	196	163	1500	4420
1/20	-	-	-	-	171	141	1380	4700	148	122	1500	5010
1/25	-	-	-	-	141	116	1390	5100	124	101	1520	5420
1/30	-	-	-	-	149	116	1710	5110	129	100	1860	5440
1/40	-	-	-	-	104	80.9	1580	5920	92.4	71.0	1730	6280
1/50	-	-	-	-	81.9	62.5	1490	6490	71.8	54.4	1620	6910
1/60	-	-	-	-	65.6	49.2	1380	7000	57.4	42.8	1500	7000

INPUT rpm RATIO	900				600				300			
	INPUT HP	OUTPUT HP	OUTPUT T kgf-m	OUTPUT O.H.L kgf	INPUT HP	OUTPUT HP	OUTPUT T kgf-m	OUTPUT O.H.L kgf	INPUT HP	OUTPUT HP	OUTPUT T kgf-m	OUTPUT O.H.L kgf
1/10	201	170	1400	4310	158	133	1640	4810	104	85.5	2100	5830
1/15	163	135	1670	4790	127	104	1930	5360	84.7	67.1	2480	6490
1/20	126	103	1680	5410	98.6	79.5	1940	6070	63.9	49.6	2430	7000
1/25	103	84.4	1680	5880	81.5	65.0	1940	6600	52.5	40.1	2390	7000
1/30	110	85.1	2100	5860	90.7	68.7	2540	6440	48.6	34.8	2580	7000
1/40	77.5	59.0	1920	6820	61.0	45.1	2200	7000	38.0	26.3	2580	7000
1/50	59.9	45.0	1790	7000	46.8	33.9	2020	7000	30.5	20.5	2450	7000
1/60	48.2	35.4	1660	7000	37.4	26.4	1860	7000	24.6	16.0	2260	7000

MODEL 축배치 및 회전방향 도면

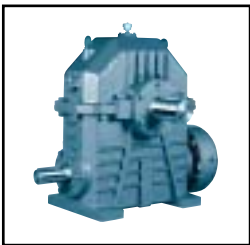

WB-450

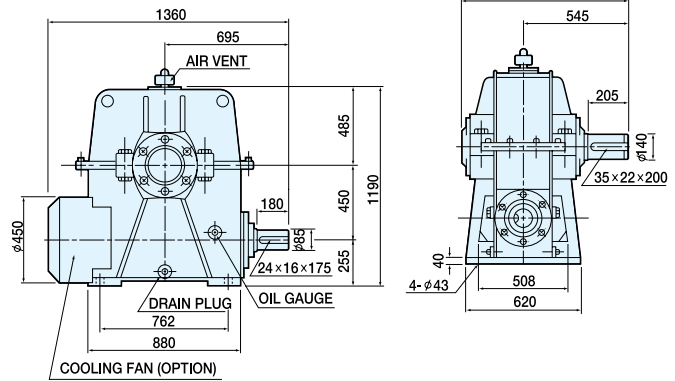
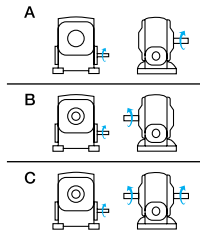

WV-450

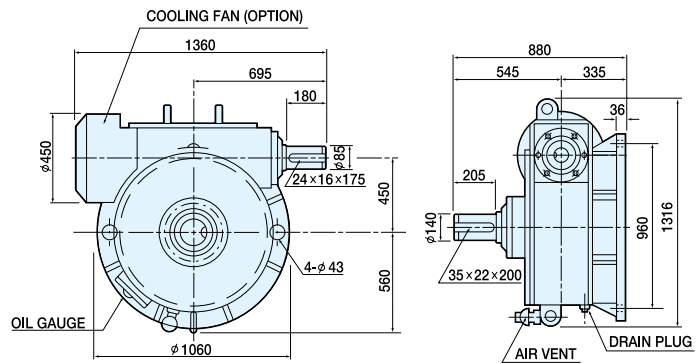
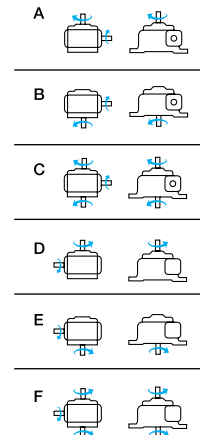

전동능력표

수치는 1일 8~10시간 연속 운전이고 균일 하중의 수치입니다.

INPUT rpm RATIO	1800				1500				1200			
	INPUT HP	OUTPUT HP	OUTPUT T kgf-m	OUTPUT O.H.L kgf	INPUT HP	OUTPUT HP	OUTPUT T kgf-m	OUTPUT O.H.L kgf	INPUT HP	OUTPUT HP	OUTPUT T kgf-m	OUTPUT O.H.L kgf
1/10	-	-	-	-	-	-	-	-	299	254	1570	4730
1/15	-	-	-	-	-	-	-	-	269	225	2080	5060
1/20	-	-	-	-	229	190	1860	5440	201	167	2040	5770
1/25	-	-	-	-	188	154	1880	5930	164	134	2040	6310
1/30	-	-	-	-	-	-	-	-	183	143	2660	6140
1/40	-	-	-	-	144	112	2190	6800	126	98.2	2400	7220
1/50	-	-	-	-	107	81.5	1980	7610	93.7	71.1	2160	8100
1/60	-	-	-	-	84.8	63.2	1840	8270	73.1	54.3	1970	8830

INPUT rpm RATIO	900				600				300			
	INPUT HP	OUTPUT HP	OUTPUT T kgf-m	OUTPUT O.H.L kgf	INPUT HP	OUTPUT HP	OUTPUT T kgf-m	OUTPUT O.H.L kgf	INPUT HP	OUTPUT HP	OUTPUT T kgf-m	OUTPUT O.H.L kgf
1/10	255	216	1780	5090	200	168	2080	5680	131	108	2670	6880
1/15	226	188	2320	5460	176	145	2690	6100	108	87.2	3230	7380
1/20	171	141	2300	6220	133	108	2640	6980	84.0	65.9	3230	8550
1/25	137	112	2280	6830	108	86.8	2640	7650	69.0	53.0	3230	9430
1/30	155	121	3000	6600	113	87.2	3230	7300	59.4	43.6	3230	9130
1/40	106	81.8	2670	7820	83.6	62.7	3070	8780	46.7	32.9	3230	10000
1/50	78.5	58.9	2390	8800	61.5	44.7	2720	9910	39.1	26.5	3230	10000
1/60	61.5	45.1	2190	9600	47.9	33.8	2460	10000	31.6	20.6	3000	10000

Single Worm Reducer/1단 웜 감속기

MODEL 축배치 및 회전방향 도 면

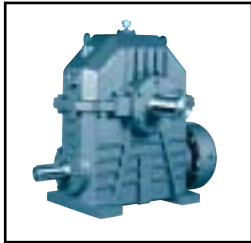

WB-500

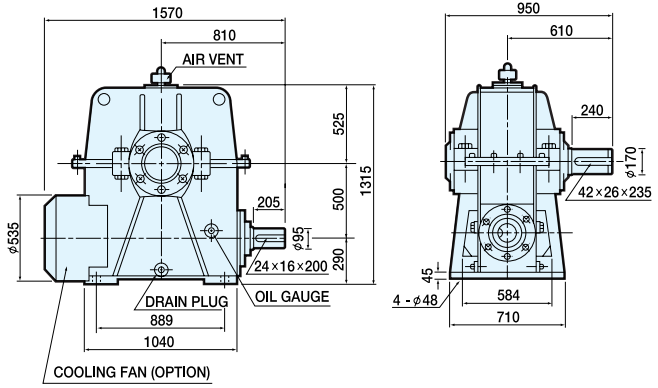
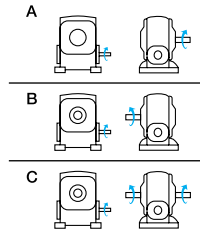

WV-500

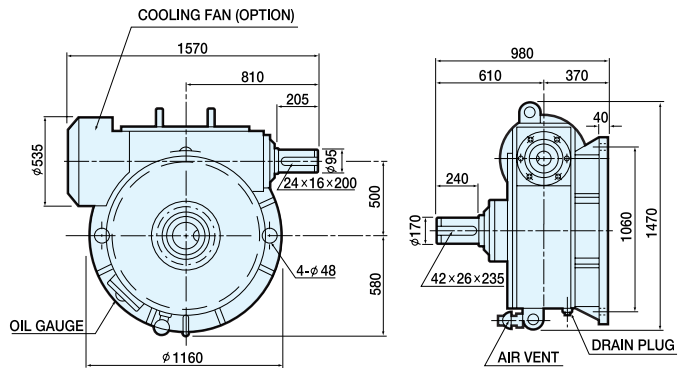
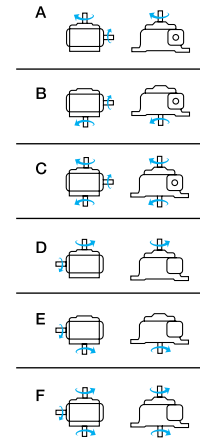

전동능력표

수치는 1일 8~10시간 연속 운전이고 균일 하중의 수치입니다.

INPUT rpm RATIO	1800				1500				1200			
	INPUT HP	OUTPUT HP	OUTPUT T kgf-m	OUTPUT O.H.L kgf	INPUT HP	OUTPUT HP	OUTPUT T kgf-m	OUTPUT O.H.L kgf	INPUT HP	OUTPUT HP	OUTPUT T kgf-m	OUTPUT O.H.L kgf
1/10	-	-	-	-	-	-	-	-	400	340	2090	13000
1/15	-	-	-	-	-	-	-	-	348	290	2680	13000
1/20	-	-	-	-	-	-	-	-	265	220	2690	13000
1/25	-	-	-	-	248	203	2470	13000	215	176	2680	13000
1/30	-	-	-	-	-	-	-	-	235	184	3400	13000
1/40	-	-	-	-	-	-	-	-	164	127	3120	13000
1/50	-	-	-	-	139	106	2580	13000	122	92.9	2820	13000
1/60	-	-	-	-	110	82.0	2390	13000	95.4	70.8	2580	13000

INPUT rpm RATIO	900				600				300			
	INPUT HP	OUTPUT HP	OUTPUT T kgf-m	OUTPUT O.H.L kgf	INPUT HP	OUTPUT HP	OUTPUT T kgf-m	OUTPUT O.H.L kgf	INPUT HP	OUTPUT HP	OUTPUT T kgf-m	OUTPUT O.H.L kgf
1/10	346	294	2410	13000	270	228	2820	13000	177	146	3610	13000
1/15	296	246	3030	13000	231	191	3530	13000	151	121	4510	13000
1/20	223	184	3000	13000	174	142	3480	13000	112	89.0	4350	13000
1/25	182	149	3020	13000	148	119	3620	13000	91.4	70.7	4300	13000
1/30	199	155	3840	13000	155	119	4430	13000	100	73.8	5460	13000
1/40	138	106	3470	13000	107	81.5	3990	13000	69.5	49.7	4860	13000
1/50	102	76.8	3110	13000	79.8	58.4	3560	13000	51.6	35.4	4310	13000
1/60	79.8	58.7	2850	13000	62.1	44.3	3220	13000	41.0	27.1	3950	13000





입력중공축형 감속기의 IEC 프레임 모터 장착표(#50~#155)

입력크기 #	형번	감속비	카플링 연결시 상용 입력	IEC 플랜지형 중공축 모델			DOUBLE형 적용시(**)				
				모터 동력	모터 축경	IEC 프레임 #					
50	WU50 WB50 WV50	1/10	0.2kw	0.2kw	11mm	63	DWB80 DWV80				
		1/15, 1/20									
		1/30									
		1/40									
		1/50									
		1/60									
60	WU60 WB60 WV60	1/10	0.4kw	0.4kw	14mm	71	DWB100 DWV100				
		1/15, 1/20									
		1/30									
		1/40									
		1/50									
		1/60						0.2kw	더 큰 형번을 선정하십시오.		
70	WU70 WB70 WV70	1/10	0.75kw	0.4kw 0.75kw	19mm(※)	80L(※)	DWB120 DWV120				
		1/15, 1/20									
		1/30									
		1/40									
		1/50						0.4kw	0.4kw	14mm	71
		1/60									
80	WU80 WB80 WV80	1/10	1.5kw	0.75kw	19mm	80L	DWB135 DWV135				
		1/15, 1/20									
		1/30									
		1/40						0.75kw			
		1/50									
		1/60									
100	WU100 WB100 WV100	1/10	2.2kw	1.5kw	24mm	90L	DWB155 DWV155				
		1/15, 1/20									
		1/30									
		1/40									
		1/50						1.5kw			
		1/60									
120	WU120 WB120 WV120	1/10	3.7kw	3.7kw 2.2kw	28mm	112M 112S	DWB175 DWV175				
		1/15, 1/20									
		1/30									
		1/40									
		1/50						2.2kw	2.2kw	28mm	112S
		1/60									
135	WU135 WB135 WV135	1/10	5.5kw	5.5kw	38mm	132S	DWB200 DWV200				
		1/15, 1/20									
		1/30									
		1/40						3.7kw	3.7kw	28mm	112M
		1/50									
		1/60									
155	WU155 WB155 WV155	1/10	7.5kw	7.5kw 5.5kw	38mm	132M 132W	DWB225 DWV225				
		1/15, 1/20									
		1/30									
		1/40									
		1/50						5.5kw	5.5kw	38mm	132S
		1/60									

(※) : OPTION 품목으로, 연결축과 플랜지가 별도로 판매됩니다.

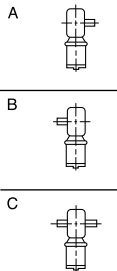
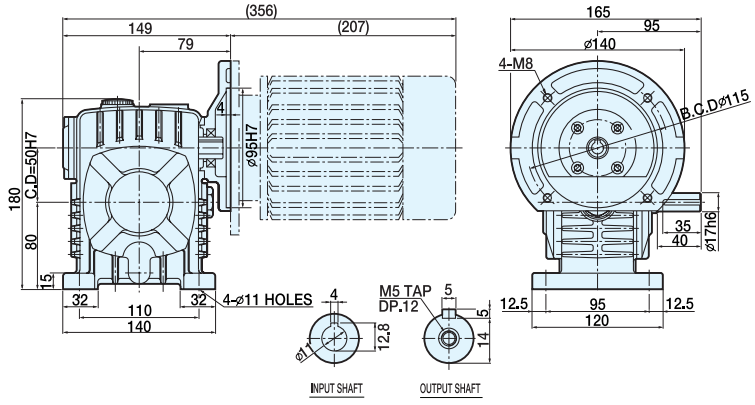
(**) : Double형의 감속비는 1/90~1/3,600 범위의 것이 있습니다.

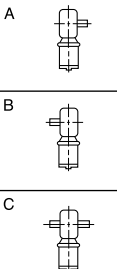
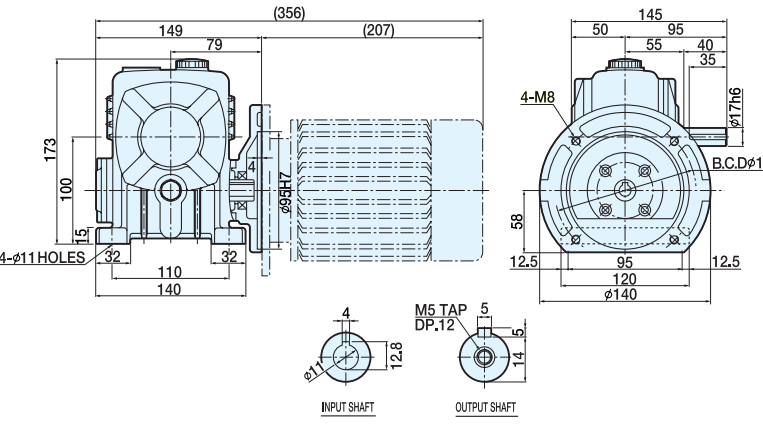
Single Worm Reducer/1단 웜 감속기

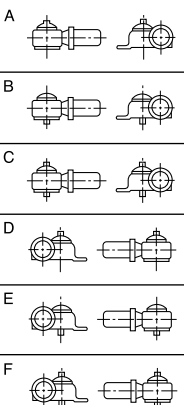
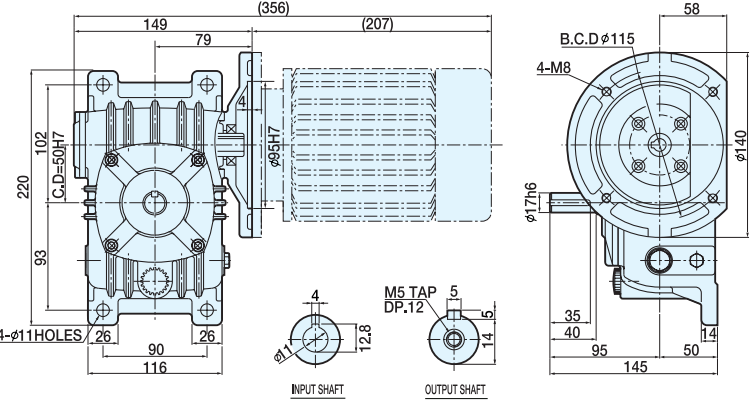
MODEL	축배치 및 회전방향	도면
 <p>WUM-50</p>		
 <p>WBM-50</p>		
 <p>WVM-50</p>		

전동능력표

수치는 1일 8~10시간 연속 운전이고 균일 하중의 수치입니다.

INPUT rpm	1800				1500			
	INPUT HP	OUTPUT HP	OUTPUT T kgf-m	OUTPUT O.H.L kgf	INPUT HP	OUTPUT HP	OUTPUT T kgf-m	OUTPUT O.H.L kgf
1/10	0.25	0.21	0.86	100	0.25	0.21	0.85	107
1/15	0.25	0.2	1.24	115	0.25	0.2	1.47	115
1/20	0.25	0.2	1.59	115	0.25	0.2	1.89	115
1/30	0.25	0.17	2.16	115	0.25	0.17	2.48	115
1/40	0.25	0.17	2.75	115	0.25	0.17	3.29	115
1/50	0.25	0.16	3.17	115	0.25	0.16	3.75	115
1/60	0.25	0.16	3.95	115	0.25	0.15	4.45	115

MODEL 축배치 및 회전방향 도 면



WUM-60

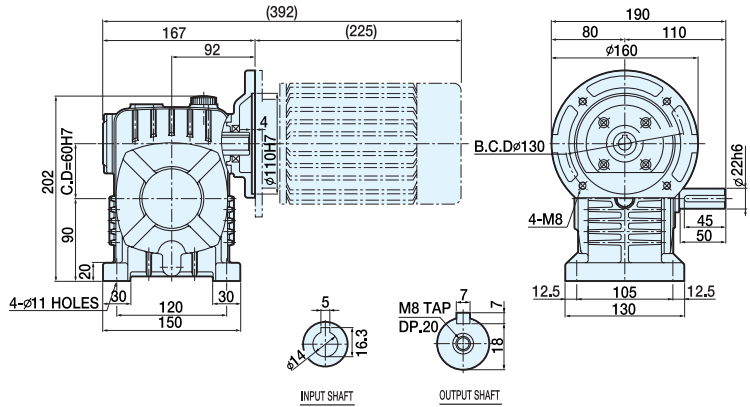
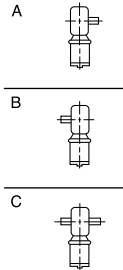

WBM-60

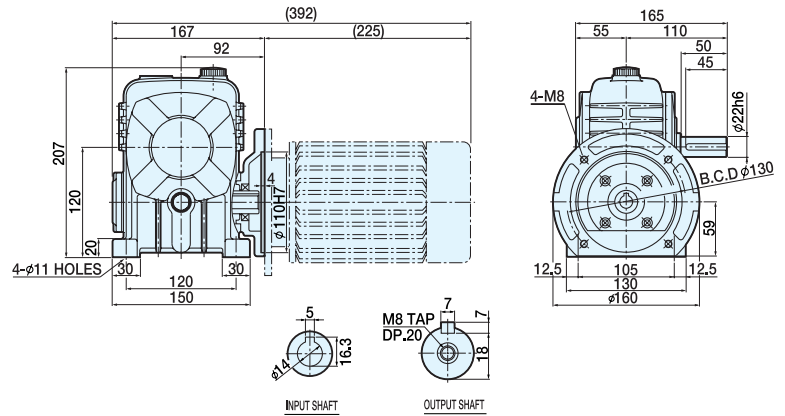
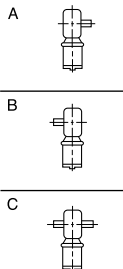

WVM-60

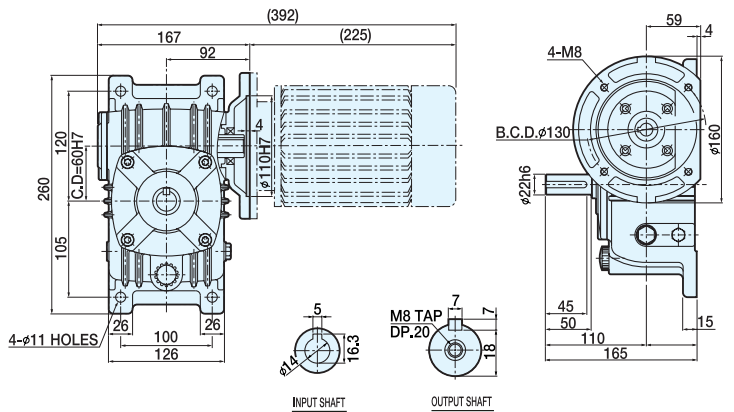
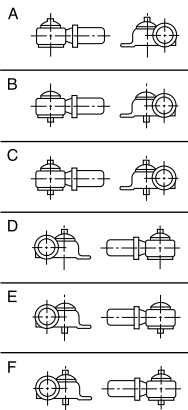

전동능력표

수치는 1일 8~10시간 연속 운전이고 균일 하중의 수치입니다.

RATIO	1800				1500			
	INPUT HP	OUTPUT HP	OUTPUT T kgf-m	OUTPUT O.H.L kgf	INPUT HP	OUTPUT HP	OUTPUT T kgf-m	OUTPUT O.H.L kgf
1/10	0.50	0.43	1.74	98	0.5	0.43	2.08	104
1/15	0.50	0.41	2.49	116	0.5	0.41	2.99	123
1/20	0.50	0.40	3.19	138	0.5	0.39	3.46	146
1/30	0.50	0.35	4.23	151	0.5	0.36	5.23	159
1/40	0.50	0.33	5.45	178	0.5	0.33	6.49	189
1/50	-	-	-	-	-	-	-	-
1/60	-	-	-	-	-	-	-	-

정신속
WORM REDUCER



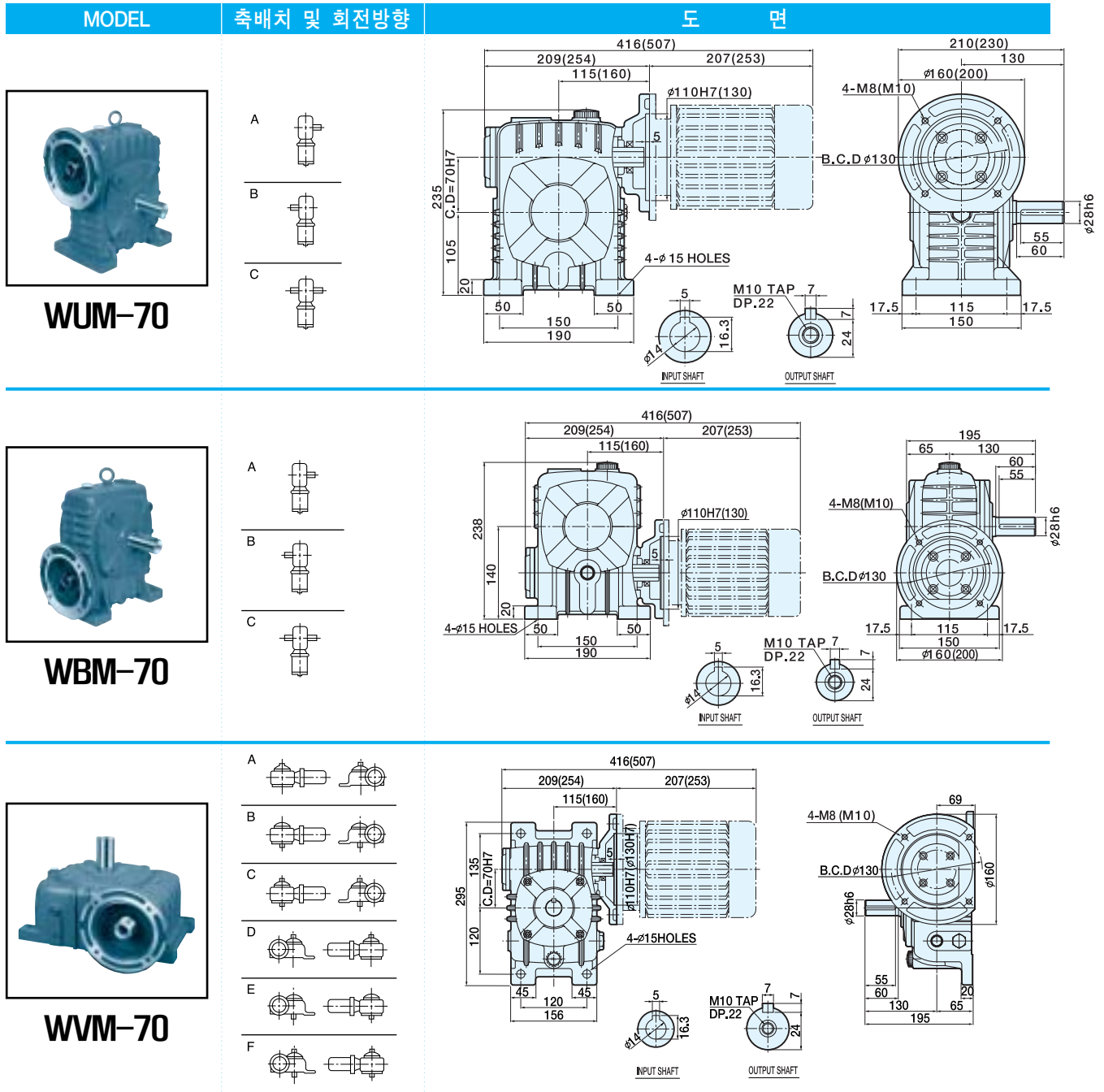

Single Worm Reducer/1단 웜 감속기

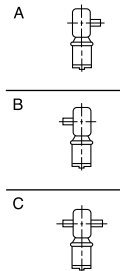
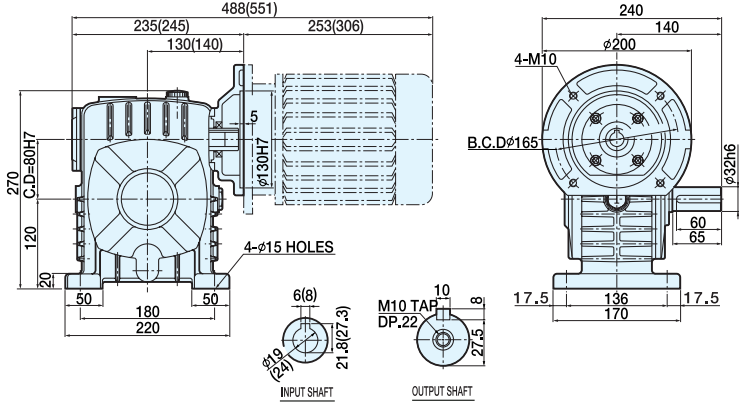

전동능력표

수치는 1일 8~10시간 연속 운전이고 균일 하중의 수치입니다.

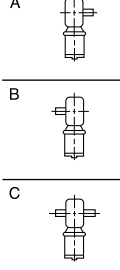
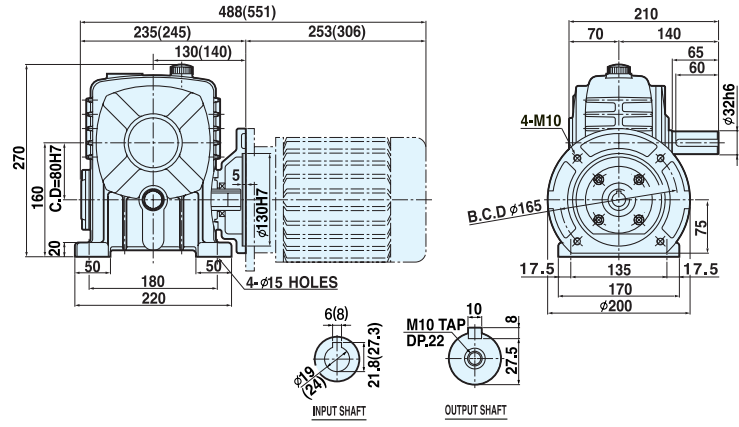
INPUT rpm	1800				1500			
	INPUT HP	OUTPUT HP	OUTPUT T kgf-m	OUTPUT O.H.L kgf	INPUT HP	OUTPUT HP	OUTPUT T kgf-m	OUTPUT O.H.L kgf
1/10	1.00	0.80	3.22	128	1.00	0.80	3.84	136
1/15	1.00	0.76	4.63	153	1.00	0.76	5.51	161
1/20	1.00	0.76	6.06	178	1.00	0.75	7.17	188
1/30	1.00	0.68	8.21	198	1.00	0.67	9.71	208
1/40	1.00	0.65	10.58	233	1.00	0.64	12.40	247
1/50	0.50	0.34	6.96	266	0.5	0.33	8.10	282
1/60	0.50	0.33	8.05	289	0.5	0.30	9.11	300

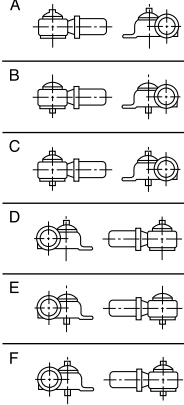
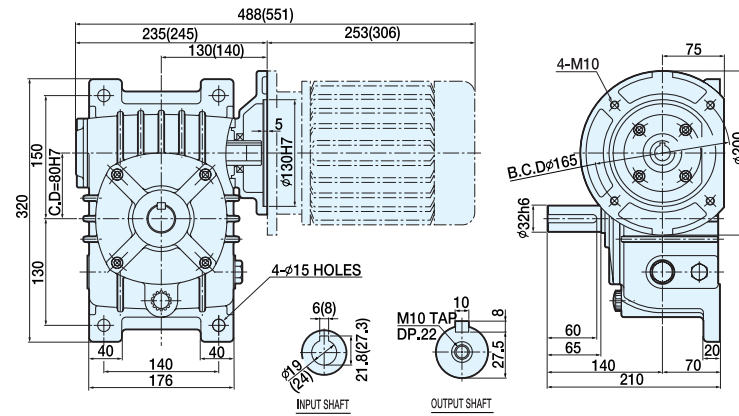
MODEL	축배치 및 회전방향	도면
 <p>WUM-80</p>		
 <p>WBM-80</p>		
 <p>WVM-80</p>		











전동능력표

수치는 1일 8~10시간 연속 운전이고 균일 하중의 수치입니다.

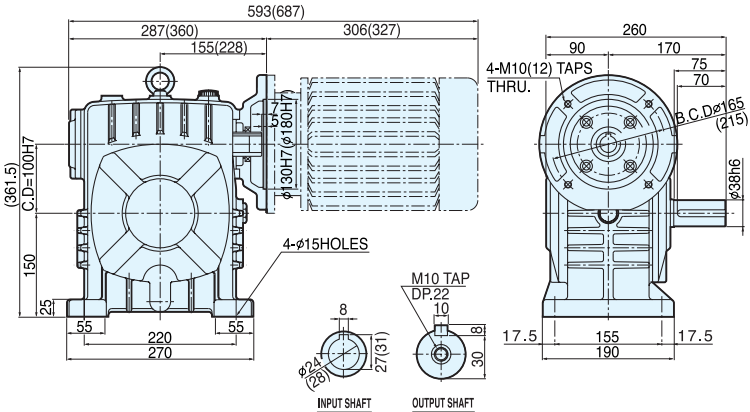
RATIO	1800				1500			
	INPUT HP	OUTPUT HP	OUTPUT T kgf-m	OUTPUT O.H.L kgf	INPUT HP	OUTPUT HP	OUTPUT T kgf-m	OUTPUT O.H.L kgf
1/10	2.00	1.65	6.59	180	2.00	1.61	7.72	191
1/15	2.00	1.57	9.41	215	2.00	1.56	11.16	228
1/20	2.00	1.53	12.22	253	2.00	1.52	14.50	267
1/30	2.00	1.44	17.13	277	2.00	1.33	19.20	294
1/40	1.00	0.65	10.64	320	1.00	0.65	12.40	340
1/50	1.00	0.65	13.10	364	1.00	0.64	15.25	385
1/60	1.00	0.60	14.28	400	0.75	0.57	15.70	400

정신축
WORM REDUCER

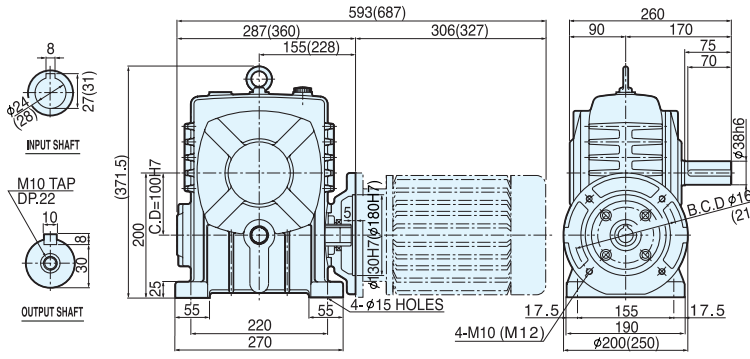

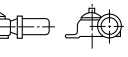
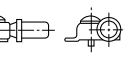
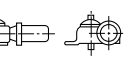
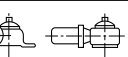
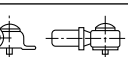
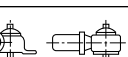
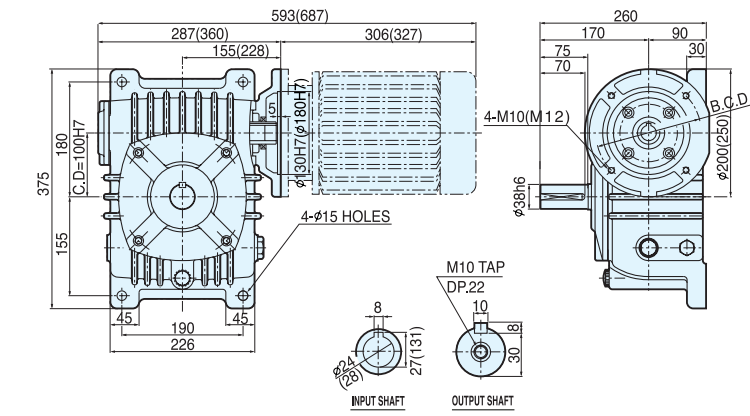

Single Worm Reducer/1단 웜 감속기

MODEL	축배치 및 회전방향	도면
 <p>WUM-100</p>	<p>A</p>  <p>B</p>  <p>C</p> 	 <p>287(360) 593(687) 306(327) 155(228) C.D.=100H7 150 25 55 220 55 270 4-φ15 HOLES φ130H7(φ180H7) 8 27(31) M10 TAP DP.22 10 30 INPUT SHAFT OUTPUT SHAFT 4-M10(12) TAPS THRU. 90 260 170 75 70 B.C.D.φ165 (215) φ38H6 17.5 155 190 17.5</p>
 <p>WBM-100</p>	<p>A</p>  <p>B</p>  <p>C</p> 	 <p>287(360) 593(687) 306(327) 155(228) C.D.=100H7 200 25 55 220 55 270 4-φ15 HOLES φ130H7(φ180H7) 8 27(31) M10 TAP DP.22 10 30 INPUT SHAFT OUTPUT SHAFT 4-M10 (M12) 17.5 155 190 17.5 90 260 170 75 70 B.C.D.φ165 (215) φ38H6 φ200(250)</p>
 <p>WVM-100</p>	<p>A</p>  <p>B</p>  <p>C</p>  <p>D</p>  <p>E</p>  <p>F</p> 	 <p>287(360) 593(687) 306(327) 155(228) C.D.=100H7 180 375 155 45 190 45 226 4-φ15 HOLES φ130H7(φ180H7) 8 27(31) M10 TAP DP.22 10 30 INPUT SHAFT OUTPUT SHAFT 4-M10(M12) φ38H6 17.5 155 190 17.5 90 260 170 75 70 B.C.D.φ165 (215) φ200(250)</p>

전동능력표

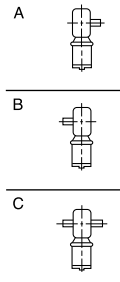
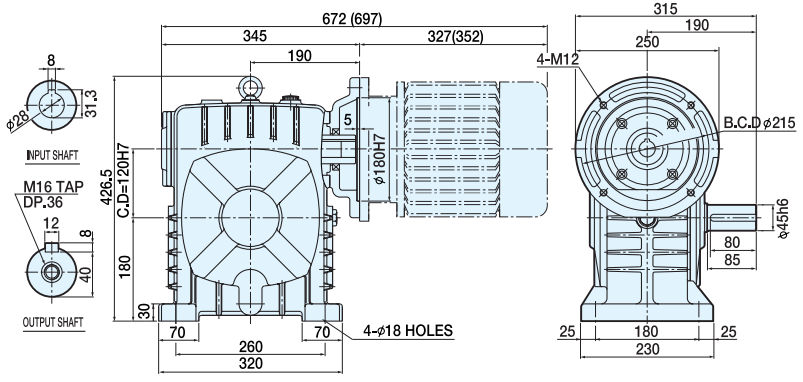
수치는 1일 8~10시간 연속 운전이고 균일 하중의 수치입니다.

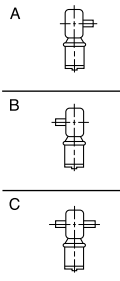
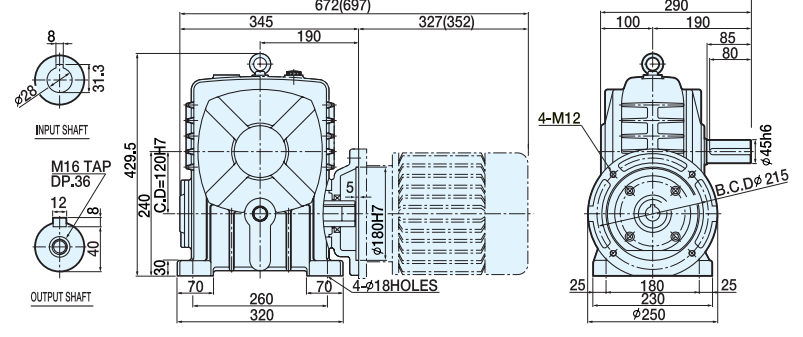
INPUT rpm	1800				1500			
	INPUT HP	OUTPUT HP	OUTPUT T kgf-m	OUTPUT O.H.L kgf	INPUT HP	OUTPUT HP	OUTPUT T kgf-m	OUTPUT O.H.L kgf
1/10	3.00	2.46	9.81	167	3.00	2.44	11.67	177
1/15	3.00	2.37	14.20	207	3.00	2.35	16.84	217
1/20	3.00	2.33	18.66	204	3.00	2.32	22.18	252
1/30	3.00	2.13	22.57	265	3.00	2.09	30.05	281
1/40	2.00	1.39	22.16	316	2.00	1.36	26.16	336
1/50	2.00	1.33	26.61	364	2.00	1.31	31.39	386
1/60	2.00	1.27	30.40	400	1.50	1.31	32.70	424

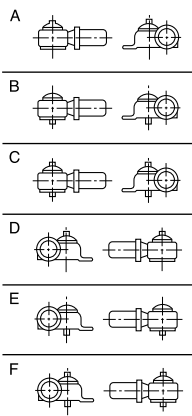
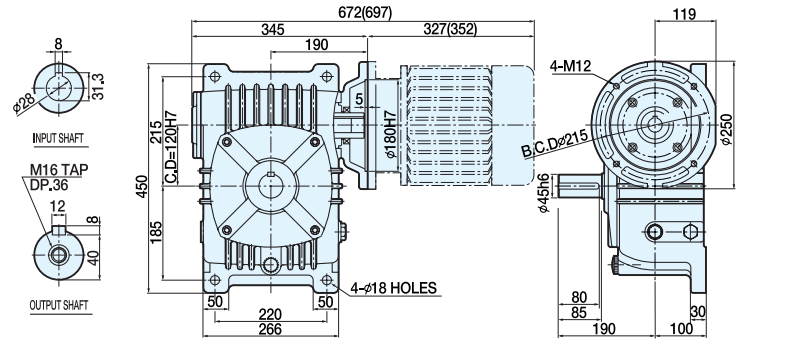
MODEL	축배치 및 회전방향	도면
 <p>WUM-120</p>		
 <p>WBM-120</p>		
 <p>WVM-120</p>		





전동능력표

수치는 1일 8~10시간 연속 운전이고 균일 하중의 수치입니다.

INPUT rpm	1800				1500			
	INPUT HP	OUTPUT HP	OUTPUT T kgf-m	OUTPUT O.H.L kgf	INPUT HP	OUTPUT HP	OUTPUT T kgf-m	OUTPUT O.H.L kgf
1/10	5.00	4.13	16.65	177	5.00	4.11	19.63	184
1/15	5.00	3.99	23.86	218	5.00	3.96	28.41	231
1/20	5.00	3.86	30.76	270	5.00	3.82	36.54	285
1/30	5.00	3.62	43.21	285	5.00	3.57	51.14	302
1/40	3.00	2.04	32.49	357	3.00	2.00	38.33	380
1/50	3.00	2.08	41.56	404	3.00	2.05	49.05	429
1/60	3.00	1.95	46.68	453	2.75	1.81	51.90	481

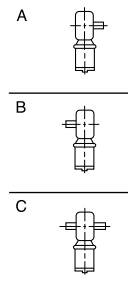
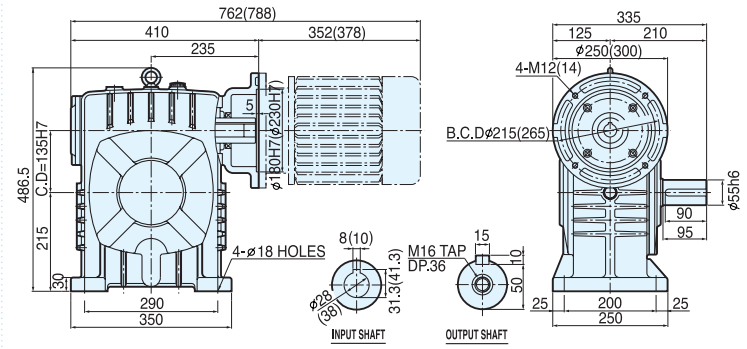
worms
WORM REDUCER

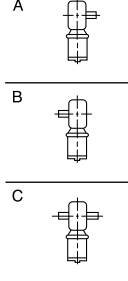
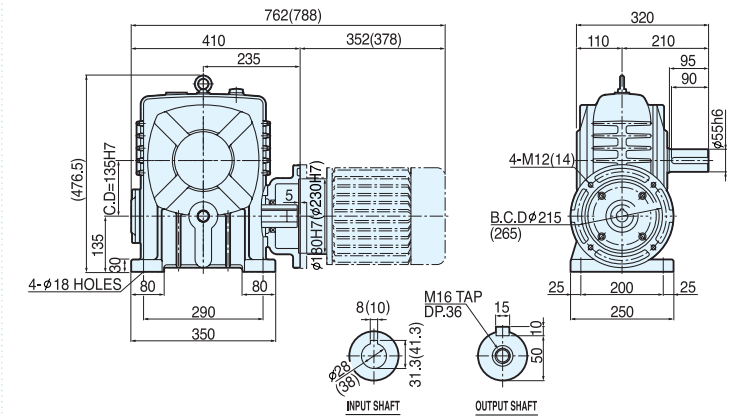
Single Worm Reducer/1단 웜 감속기

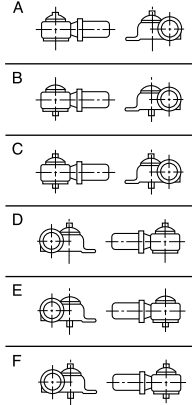
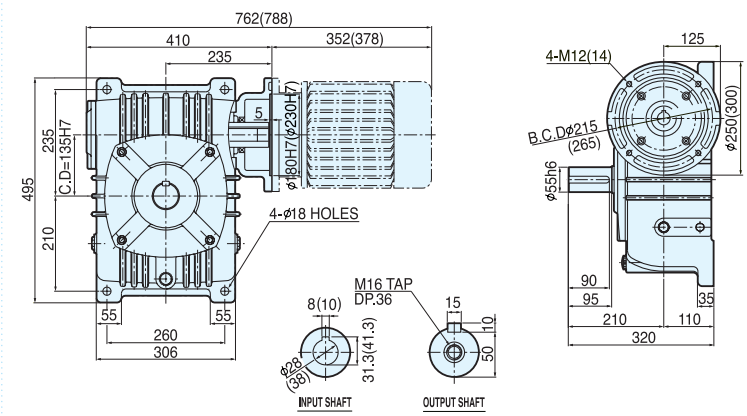
MODEL	축배치 및 회전방향	도면
 <p>WUM-135</p>		
 <p>WBM-135</p>		
 <p>WVM-135</p>		

전동능력표

수치는 1일 8~10시간 연속 운전이고 균일 하중의 수치입니다.

INPUT rpm	1800				1500			
	INPUT HP	OUTPUT HP	OUTPUT T kgf-m	OUTPUT O.H.L kgf	INPUT HP	OUTPUT HP	OUTPUT T kgf-m	OUTPUT O.H.L kgf
1/10	7.5	6.25	24.9	304	7.5	6.23	29.7	319
1/15	7.5	6.09	36.3	362	7.5	6.04	43.3	384
1/20	7.5	6.00	47.8	426	7.5	5.94	56.7	449
1/30	7.5	5.57	66.6	468	7.5	5.50	78.8	496
1/40	5.0	3.62	57.8	566	5.0	3.81	72.8	599
1/50	5.0	3.52	70.1	650	5.0	3.80	90.7	691
1/60	5.0	2.80	67.0	724	5.0	3.72	106.6	769

MODEL 축배치 및 회전방향 도면

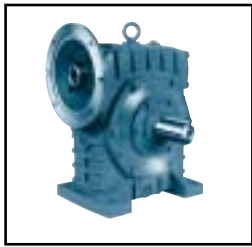

WUM-155

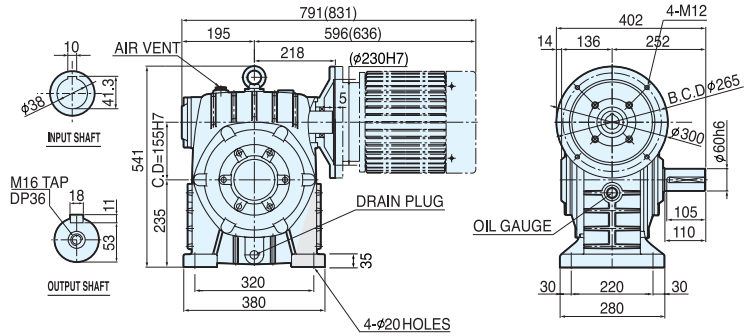
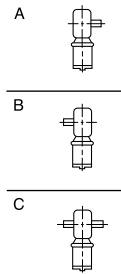

WBM-155

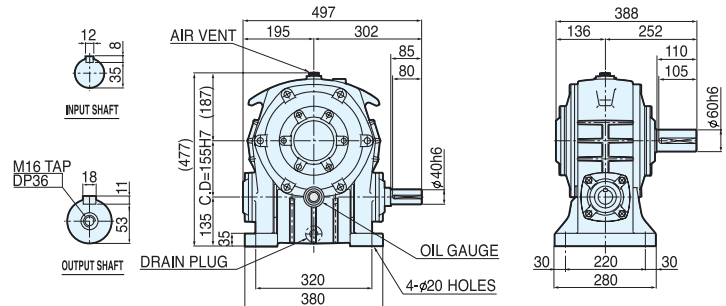
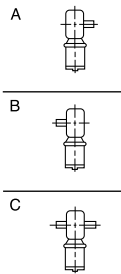

WVM-155

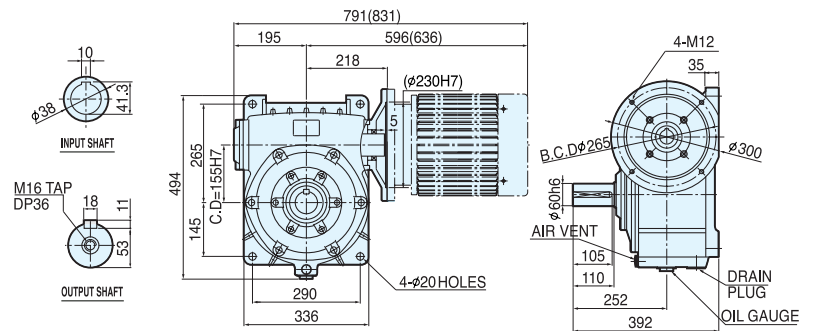
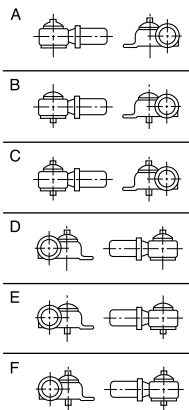

전동능력표

수치는 1일 8~10시간 연속 운전이고 균일 하중의 수치입니다.

RATIO	1800				1500			
	INPUT HP	OUTPUT HP	OUTPUT T kg·m	OUTPUT O.H.L kgf	INPUT HP	OUTPUT HP	OUTPUT T kg·m	OUTPUT O.H.L kgf
1/10	10.0	8.34	33.1	1500	10.0	8.30	39.6	1500
1/15	10.0	8.12	48.3	1500	10.0	8.05	57.5	1500
1/20	10.0	8.00	63.6	1500	10.0	7.92	75.4	1500
1/30	10.0	7.44	88.6	1500	10.0	7.34	105.0	1500
1/40	7.50	5.36	85.4	1500	7.50	5.32	101.7	1500
1/50	7.50	4.97	98.9	1500	6.50	4.40	105.0	1500
1/60	6.00	3.99	95.3	1500	5.00	3.57	102.0	1500

Double Worm Reducer/2단 웜 감속기

MODEL 축배치 및 회전방향 도 면

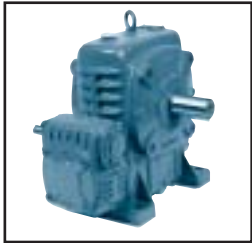

DWB-60

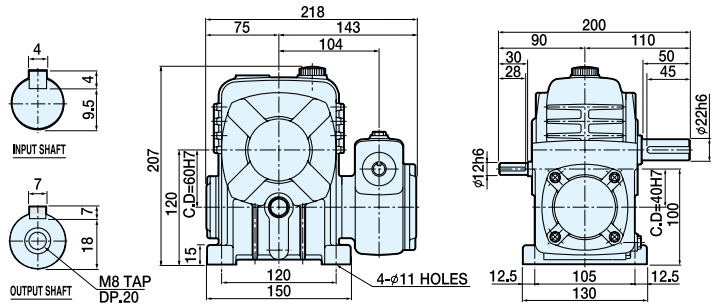
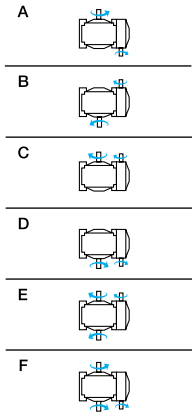

DWV-60

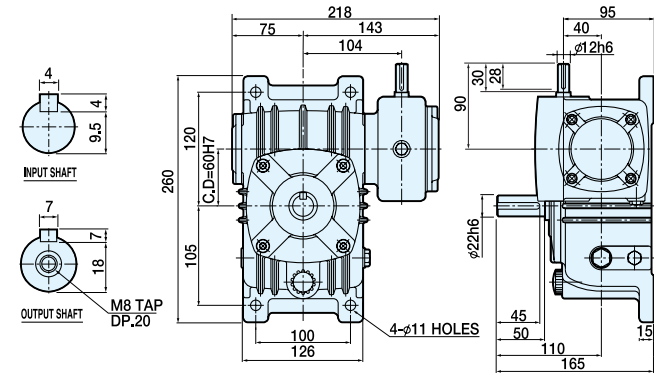
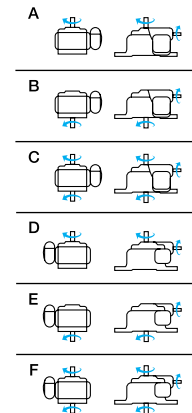

전동능력표

수치는 1일 8~10시간 연속 운전이고 균일 하중의 수치입니다.

INPUT rpm RATIO	1800				1500				1200			
	INPUT HP	OUTPUT HP	OUTPUT T kgf-m	OUTPUT O.H.L kgf	INPUT HP	OUTPUT HP	OUTPUT T kgf-m	OUTPUT O.H.L kgf	INPUT HP	OUTPUT HP	OUTPUT T kgf-m	OUTPUT O.H.L kgf
1/200	0.32	0.13	11.6	200	0.27	0.12	11.6	200	0.21	0.08	11.6	200
1/300	0.23	0.08	11.6	200	0.20	0.08	11.6	200	0.16	0.05	11.6	200
1/400	0.19	0.07	11.6	200	0.16	0.05	11.6	200	0.12	0.04	11.6	200
1/500	0.16	0.04	11.6	200	0.13	0.04	11.6	200	0.12	0.03	11.6	200
1/600	0.13	0.04	11.6	200	0.12	0.04	11.6	200	0.09	0.03	11.6	200
1/800	0.12	0.03	11.6	200	0.11	0.03	11.6	200	0.08	0.01	11.6	200
1/900	0.11	0.03	11.6	200	0.09	0.01	11.6	200	0.08	0.01	11.6	200

INPUT rpm RATIO	900				600			
	INPUT HP	OUTPUT HP	OUTPUT T kgf-m	OUTPUT O.H.L kgf	INPUT HP	OUTPUT HP	OUTPUT T kgf-m	OUTPUT O.H.L kgf
1/200	0.16	0.07	11.6	200	0.12	0.04	11.6	200
1/300	0.12	0.04	11.6	200	0.08	0.03	11.6	200
1/400	0.09	0.03	11.6	200	0.07	0.01	11.6	200
1/500	0.08	0.01	11.6	200	0.05	0.01	11.6	200
1/600	0.08	0.01	11.6	200	0.05	0.01	11.6	200
1/800	0.07	0.01	11.6	200	0.04	0.01	11.6	200
1/900	0.05	0.01	11.6	200	0.04	0.01	11.6	200

MODEL 축배치 및 회전방향 도면



DWB-70

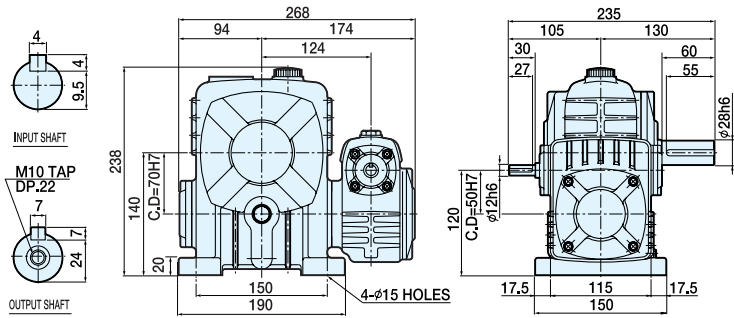
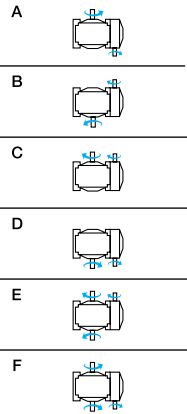

DWV-70

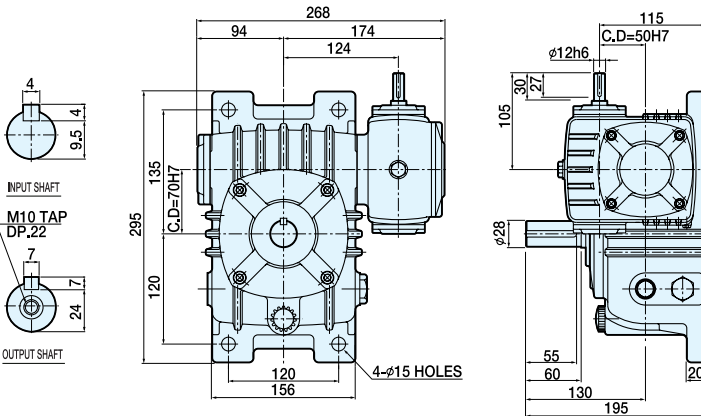
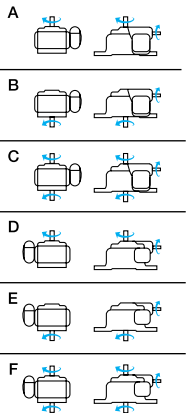

전동능력표

수치는 1일 8~10시간 연속 운전이고 균일 하중의 수치입니다.

INPUT rpm RATIO	1800				1500				1200			
	INPUT HP	OUTPUT HP	OUTPUT T kgf-m	OUTPUT O.H.L kgf	INPUT HP	OUTPUT HP	OUTPUT T kgf-m	OUTPUT O.H.L kgf	INPUT HP	OUTPUT HP	OUTPUT T kgf-m	OUTPUT O.H.L kgf
1/200	0.63	0.31	25.0	300	0.52	0.25	25.0	300	0.41	0.20	25.0	300
1/300	0.44	0.20	25.0	300	0.36	0.16	25.0	300	0.28	0.12	25.0	300
1/400	0.36	0.15	25.0	300	0.31	0.12	25.0	300	0.24	0.09	25.0	300
1/500	0.31	0.12	25.0	300	0.24	0.09	25.0	300	0.20	0.08	25.0	300
1/600	0.25	0.09	25.0	300	0.20	0.08	25.0	300	0.15	0.05	25.0	300
1/800	0.24	0.07	25.0	300	0.19	0.05	25.0	300	0.16	0.04	25.0	300
1/900	0.21	0.05	25.0	300	0.15	0.04	25.0	300	0.12	0.04	25.0	300

INPUT rpm RATIO	900				600			
	INPUT HP	OUTPUT HP	OUTPUT T kgf-m	OUTPUT O.H.L kgf	INPUT HP	OUTPUT HP	OUTPUT T kgf-m	OUTPUT O.H.L kgf
1/200	0.32	0.15	25.0	300	0.23	0.09	25.0	300
1/300	0.23	0.09	25.0	300	0.13	0.05	25.0	300
1/400	0.17	0.07	25.0	300	0.13	0.05	25.0	300
1/500	0.16	0.05	25.0	300	0.12	0.04	25.0	300
1/600	0.12	0.04	25.0	300	0.08	0.03	25.0	300
1/800	0.09	0.03	25.0	300	0.07	0.01	25.0	300
1/900	0.09	0.03	25.0	300	0.07	0.01	25.0	300

시속
WORM REDUCER

Double Worm Reducer/2단 웜 감속기

MODEL 축배치 및 회전방향 도 면



DWB-80

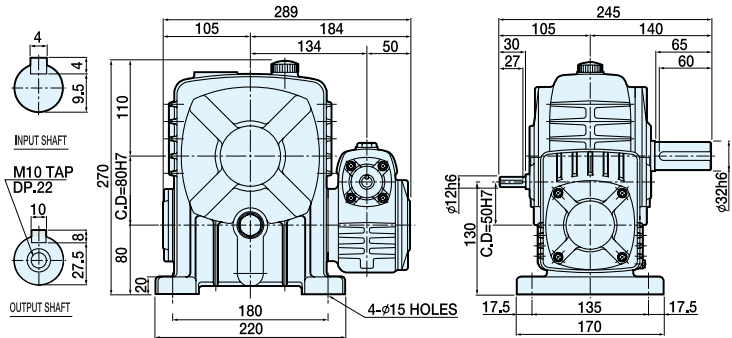
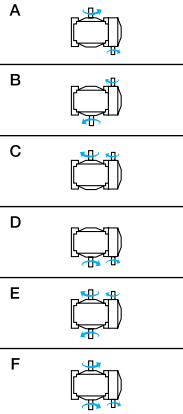

DWV-80

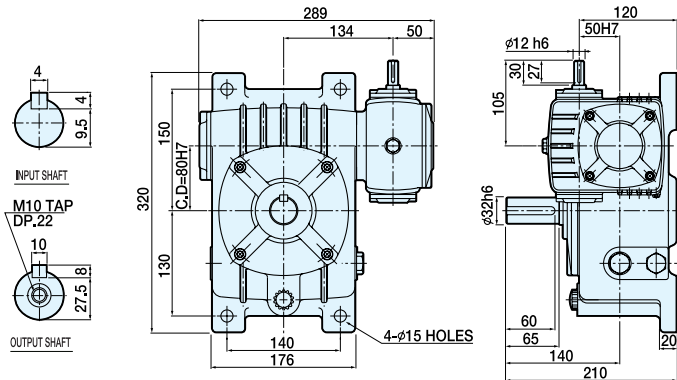
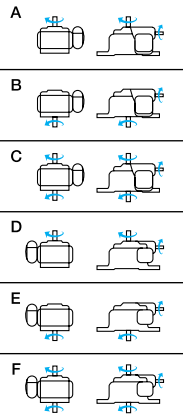

전동능력표

수치는 1일 8~10시간 연속 운전이고 균일 하중의 수치입니다.

INPUT rpm RATIO	1800				1500				1200			
	INPUT HP	OUTPUT HP	OUTPUT T kgf-m	OUTPUT O.H.L kgf	INPUT HP	OUTPUT HP	OUTPUT T kgf-m	OUTPUT O.H.L kgf	INPUT HP	OUTPUT HP	OUTPUT T kgf-m	OUTPUT O.H.L kgf
1/200	0.89	0.41	33.8	400	0.64	0.36	35.0	400	0.53	0.28	35.0	400
1/300	0.64	0.28	35.0	400	0.45	0.24	35.0	400	0.37	0.19	35.0	400
1/400	0.53	0.20	35.0	400	0.36	0.17	35.0	400	0.28	0.13	35.0	400
1/500	0.44	0.16	35.0	400	0.29	0.13	35.0	400	0.24	0.11	35.0	400
1/600	0.39	0.13	35.0	400	0.27	0.12	35.0	400	0.20	0.08	35.0	400
1/800	0.45	0.09	35.0	400	0.28	0.08	35.0	400	0.23	0.07	35.0	400
1/900	0.29	0.08	35.0	400	0.21	0.08	35.0	400	0.16	0.05	35.0	400

INPUT rpm RATIO	900				600			
	INPUT HP	OUTPUT HP	OUTPUT T kgf-m	OUTPUT O.H.L kgf	INPUT HP	OUTPUT HP	OUTPUT T kgf-m	OUTPUT O.H.L kgf
1/200	0.40	0.21	35.0	400	0.28	0.14	35.0	400
1/300	0.28	0.14	35.0	400	0.19	0.09	35.0	400
1/400	0.21	0.10	35.0	400	0.16	0.07	35.0	400
1/500	0.17	0.08	35.0	400	0.12	0.04	35.0	400
1/600	0.16	0.07	35.0	400	0.09	0.04	35.0	400
1/800	0.16	0.05	35.0	400	0.11	0.03	35.0	400
1/900	0.12	0.04	35.0	400	0.09	0.03	35.0	400

MODEL 축배치 및 회전방향 도면

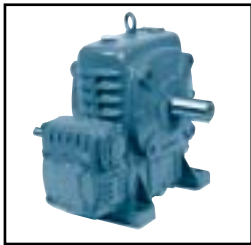

DWB-100

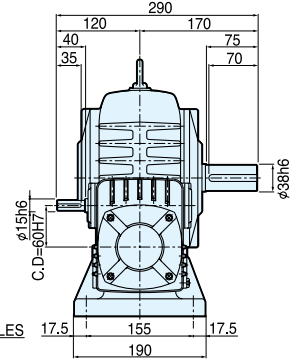
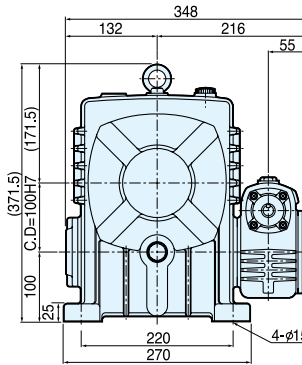
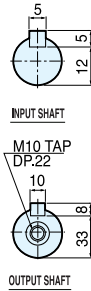
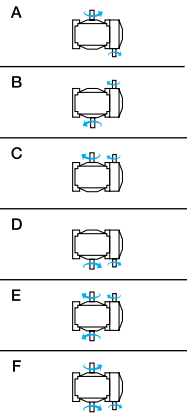

DWV-100

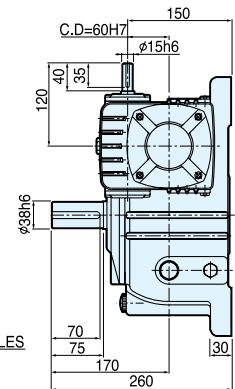
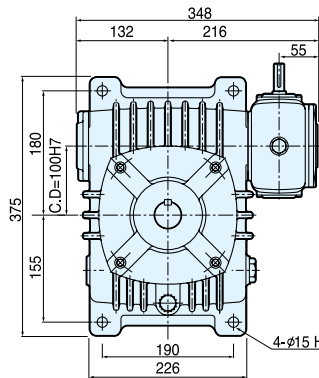
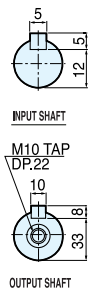
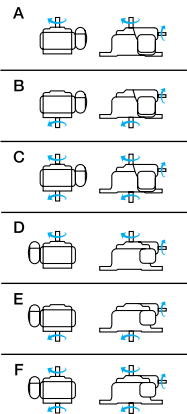



전동능력표



수치는 1일 8~10시간 연속 운전이고 균일 하중의 수치입니다.

INPUT rpm RATIO	1800				1500				1200			
	INPUT HP	OUTPUT HP	OUTPUT T kgf-m	OUTPUT O.H.L kgf	INPUT HP	OUTPUT HP	OUTPUT T kgf-m	OUTPUT O.H.L kgf	INPUT HP	OUTPUT HP	OUTPUT T kgf-m	OUTPUT O.H.L kgf
1/200	1.17	0.62	50.0	575	0.95	0.52	50.0	622	0.77	0.41	50.0	650
1/300	0.84	0.40	50.0	650	0.67	0.33	50.0	650	0.54	0.27	50.0	650
1/400	0.67	0.31	50.0	650	0.52	0.26	50.0	650	0.41	0.20	50.0	650
1/500	0.58	0.25	50.0	650	0.41	0.20	50.0	650	0.35	0.16	50.0	650
1/600	0.50	0.20	50.0	650	0.39	0.17	50.0	650	0.31	0.13	50.0	650
1/800	0.52	0.15	50.0	650	0.40	0.13	50.0	650	0.32	0.09	50.0	650
1/900	0.42	0.13	50.0	650	0.31	0.11	50.0	650	0.27	0.08	50.0	650

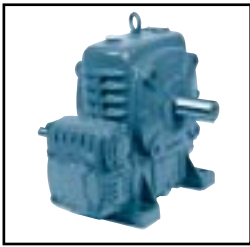
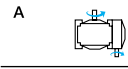
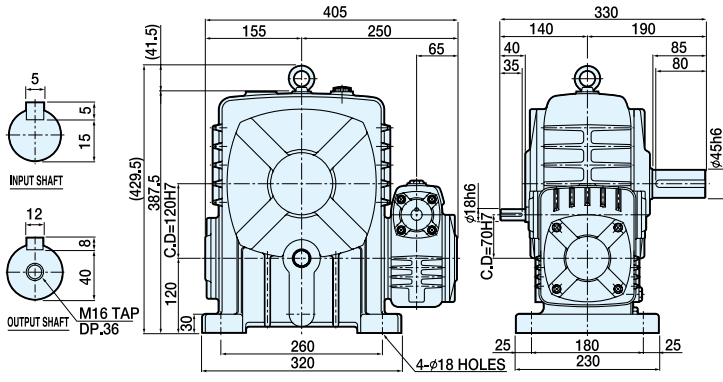
INPUT rpm RATIO	900				600			
	INPUT HP	OUTPUT HP	OUTPUT T kgf-m	OUTPUT O.H.L kgf	INPUT HP	OUTPUT HP	OUTPUT T kgf-m	OUTPUT O.H.L kgf
1/200	0.60	0.31	50.0	650	0.41	0.20	50.0	650
1/300	0.41	0.20	50.0	650	0.29	0.13	50.0	650
1/400	0.32	0.15	50.0	650	0.23	0.10	50.0	650
1/500	0.27	0.12	50.0	650	0.19	0.08	50.0	650
1/600	0.25	0.10	50.0	650	0.16	0.05	50.0	650
1/800	0.24	0.07	50.0	650	0.18	0.04	50.0	650
1/900	0.19	0.05	50.0	650	0.12	0.04	50.0	650

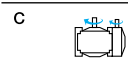
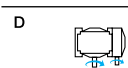
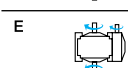
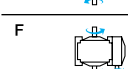
Double Worm Reducer/2단 웜 감속기

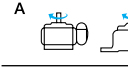
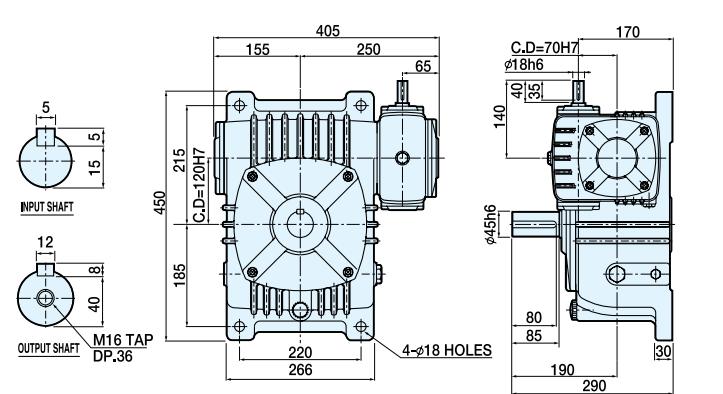
MODEL	축배치 및 회전방향	도면
 <p>DWB-120</p>	A 	
	B 	
	C 	
	D 	
	E 	
	F 	

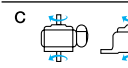
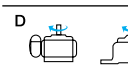
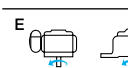
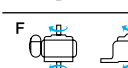
 <p>DWV-120</p>	A 	
	B 	
	C 	
	D 	
	E 	
	F 	

전동능력표

수치는 1일 8~10시간 연속 운전이고 균일 하중의 수치입니다.

INPUT rpm / RATIO	1800				1500				1200			
	INPUT HP	OUTPUT HP	OUTPUT T kgf-m	OUTPUT O.H.L kgf	INPUT HP	OUTPUT HP	OUTPUT T kgf-m	OUTPUT O.H.L kgf	INPUT HP	OUTPUT HP	OUTPUT T kgf-m	OUTPUT O.H.L kgf
1/200	2.04	1.05	84.0	618	1.72	0.87	84.0	675	1.44	0.69	84.0	749
1/300	1.47	0.70	84.0	749	1.24	0.58	84.0	814	1.01	0.45	84.0	899
1/400	1.15	0.52	84.0	854	0.96	0.43	84.0	925	0.81	0.35	84.0	1000
1/500	1.03	0.42	84.0	942	0.88	0.35	84.0	1000	0.72	0.28	84.0	1000
1/600	0.88	0.35	84.0	1000	0.75	0.29	84.0	1000	0.61	0.23	84.0	1000
1/800	0.93	0.26	84.0	1000	0.78	0.21	84.0	1000	0.67	0.17	84.0	1000
1/900	0.69	0.23	84.0	1000	0.57	0.19	84.0	1000	0.47	0.15	84.0	1000

INPUT rpm / RATIO	900				600			
	INPUT HP	OUTPUT HP	OUTPUT T kgf-m	OUTPUT O.H.L kgf	INPUT HP	OUTPUT HP	OUTPUT T kgf-m	OUTPUT O.H.L kgf
1/200	1.11	0.52	84.0	854	0.79	0.35	84.0	1000
1/300	0.81	0.35	84.0	1000	0.56	0.23	84.0	1000
1/400	0.64	0.25	84.0	1000	0.44	0.17	84.0	1000
1/500	0.57	0.21	84.0	1000	0.40	0.14	84.0	1000
1/600	0.48	0.17	84.0	1000	0.33	0.11	84.0	1000
1/800	0.32	0.13	84.0	1000	0.20	0.08	84.0	1000
1/900	0.36	0.11	84.0	1000	0.25	0.07	84.0	1000

MODEL 축배치 및 회전방향 도면

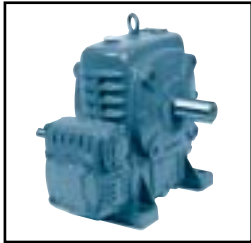

DWB-135

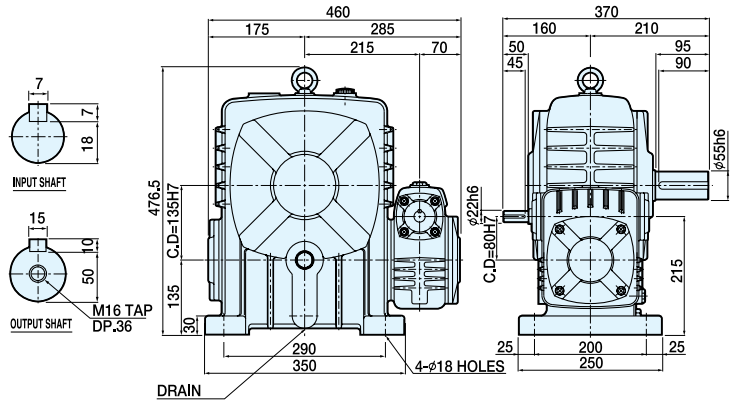
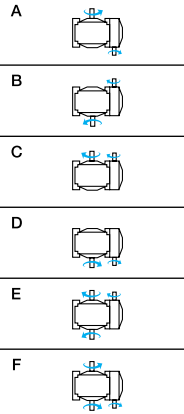

DWV-135

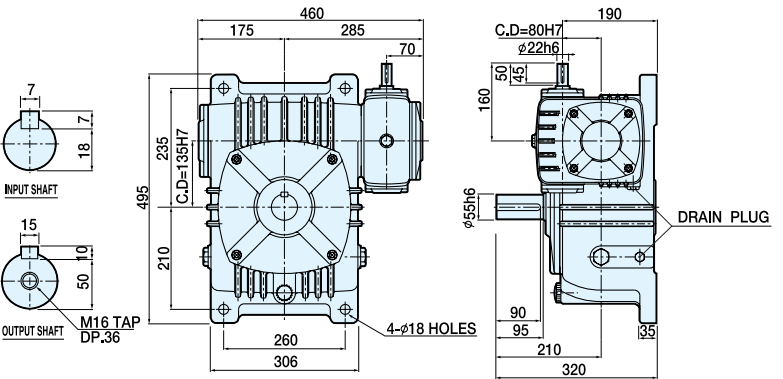
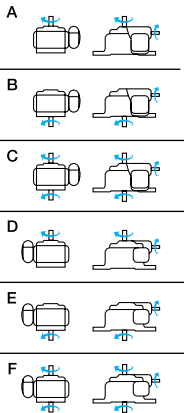

전동능력표

수치는 1일 8~10시간 연속 운전이고 균일 하중의 수치입니다.

INPUT rpm / RATIO	1800				1500				1200			
	INPUT HP	OUTPUT HP	OUTPUT T kgf-m	OUTPUT O.H.L kgf	INPUT HP	OUTPUT HP	OUTPUT T kgf-m	OUTPUT O.H.L kgf	INPUT HP	OUTPUT HP	OUTPUT T kgf-m	OUTPUT O.H.L kgf
1/200	3.13	1.75	140	960	2.37	1.45	140	1200	2.16	1.16	140	1156
1/300	2.24	1.16	140	1156	1.88	0.96	140	1200	1.56	0.78	140	1200
1/400	1.76	0.87	140	1200	1.51	0.72	140	1200	1.23	0.57	140	1200
1/500	1.47	0.69	140	1200	1.24	0.57	140	1200	1.01	0.45	140	1200
1/600	1.31	0.57	140	1200	1.09	0.48	140	1200	0.92	0.39	140	1200
1/800	1.35	0.43	140	1200	1.16	0.36	140	1200	0.96	0.29	140	1200
1/900	1.05	0.39	140	1200	1.16	0.32	140	1200	0.72	0.25	140	1200

INPUT rpm / RATIO	900				600			
	INPUT HP	OUTPUT HP	OUTPUT T kgf-m	OUTPUT O.H.L kgf	INPUT HP	OUTPUT HP	OUTPUT T kgf-m	OUTPUT O.H.L kgf
1/200	1.68	0.87	140	1200	1.18	0.58	140	1200
1/300	1.20	0.57	140	1200	0.85	0.39	140	1200
1/400	0.96	0.43	140	1200	0.68	0.28	140	1200
1/500	0.80	0.35	140	1200	0.55	0.23	140	1200
1/600	0.72	0.28	140	1200	0.50	0.19	140	1200
1/800	0.73	0.21	140	1200	0.53	0.14	140	1200
1/900	0.59	0.19	140	1200	0.39	0.12	140	1200

신축
WORM REDUCER

Double Worm Reducer/2단 웜 감속기

MODEL 축배치 및 회전방향 도 면

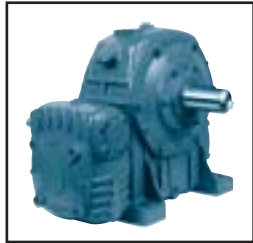

DWB-155

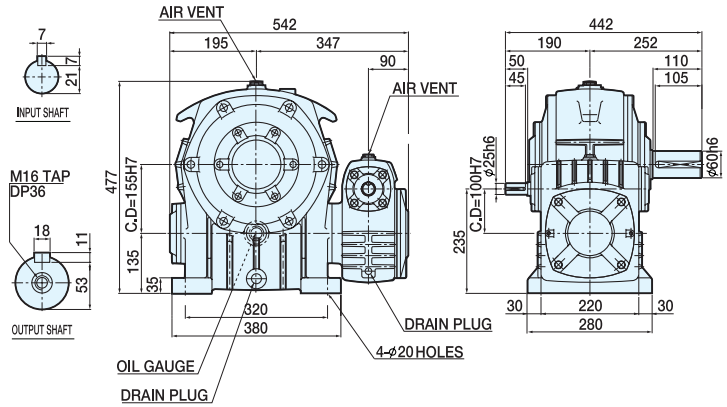
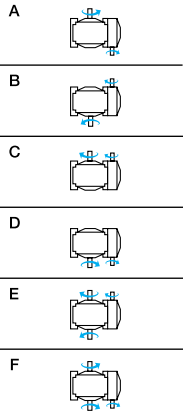

DWV-155

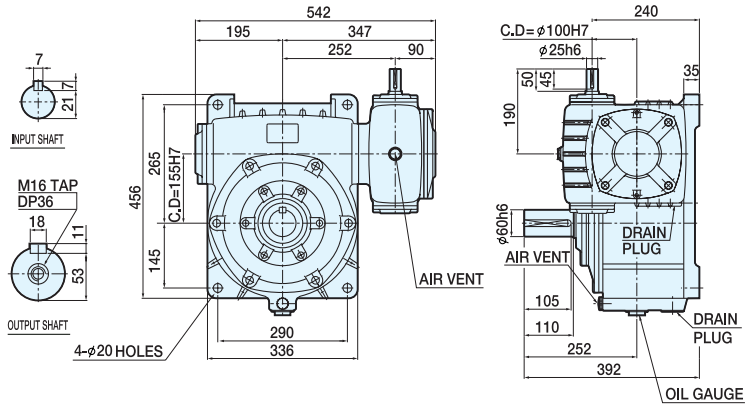
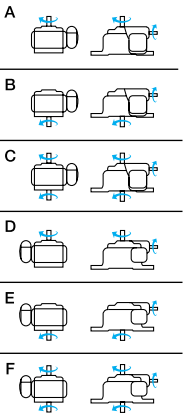

전동능력표

수치는 1일 8~10시간 연속 운전이고 균일 하중의 수치입니다.

INPUT rpm	1800				1500				1200			
	INPUT HP	OUTPUT HP	OUTPUT T kgf-m	OUTPUT O.H.L kgf	INPUT HP	OUTPUT HP	OUTPUT T kgf-m	OUTPUT O.H.L kgf	INPUT HP	OUTPUT HP	OUTPUT T kgf-m	OUTPUT O.H.L kgf
1/200	5.08	2.83	225	1500	4.54	2.48	237	1500	3.82	2.01	242	1500
1/300	3.86	2.20	242	1500	3.33	1.68	242	1500	2.73	1.34	242	1500
1/400	3.02	1.52	242	1500	2.57	1.25	242	1500	2.12	1.00	242	1500
1/500	2.50	1.20	242	1500	2.13	1.00	242	1500	1.77	0.80	242	1500
1/600	2.26	1.00	242	1500	1.96	0.84	242	1500	1.61	0.66	242	1500
1/800	2.33	0.76	242	1500	2.00	0.63	242	1500	1.64	0.49	242	1500
1/900	1.88	0.68	242	1500	1.65	0.58	242	1500	1.37	0.45	242	1500

INPUT rpm	900				600			
	INPUT HP	OUTPUT HP	OUTPUT T kgf-m	OUTPUT O.H.L kgf	INPUT HP	OUTPUT HP	OUTPUT T kgf-m	OUTPUT O.H.L kgf
1/200	2.96	1.52	242	1500	2.08	1.00	242	1500
1/300	2.12	1.00	242	1500	1.50	0.66	242	1500
1/400	1.66	0.76	242	1500	1.16	0.49	242	1500
1/500	1.37	0.60	242	1500	0.96	0.40	242	1500
1/600	1.25	0.49	242	1500	0.88	0.32	242	1500
1/800	1.32	0.37	242	1500	0.92	0.24	242	1500
1/900	1.06	0.33	242	1500	0.78	0.22	242	1500

MODEL 축배치 및 회전방향 도 면



DWB-175

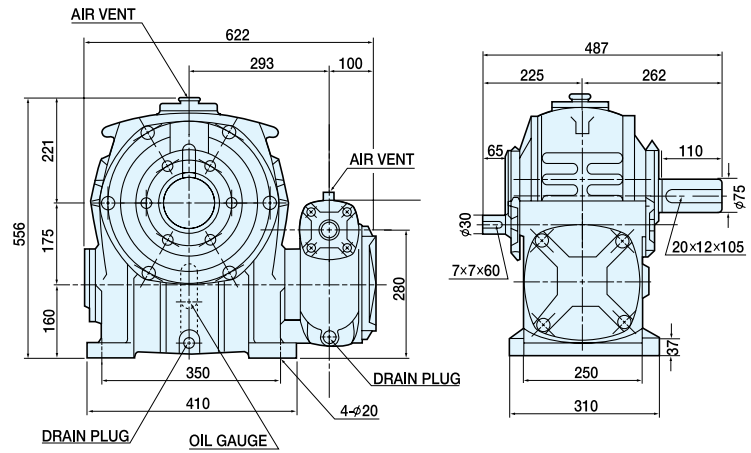
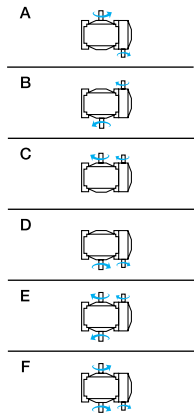

DWV-175

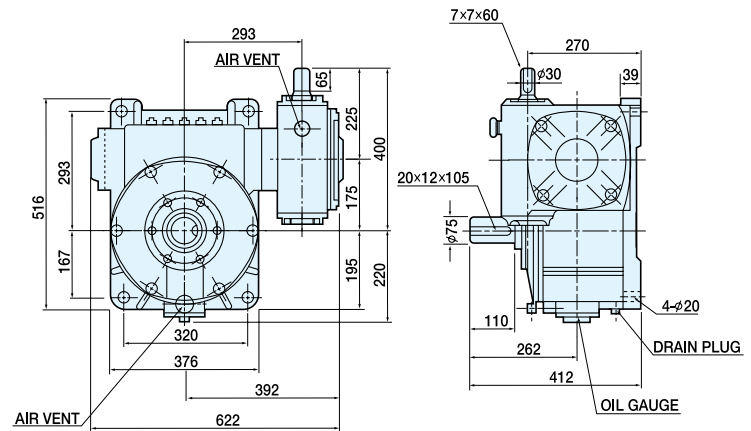
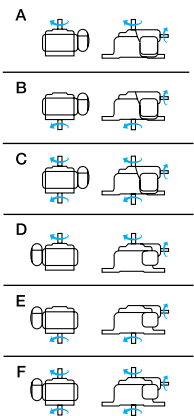









전동능력표



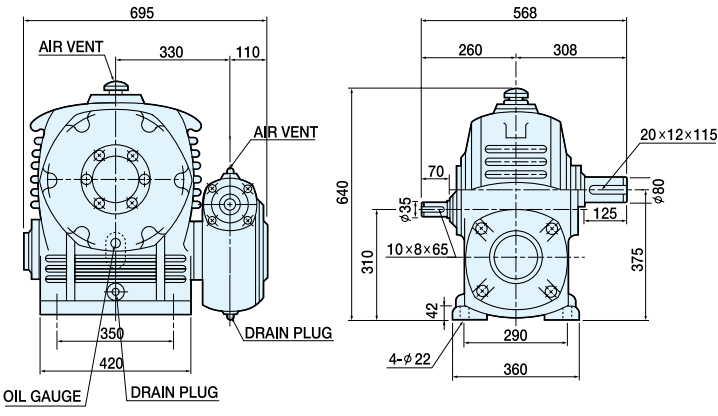





수치는 1일 8~10시간 연속 운전이고 균일 하중의 수치입니다.

RATIO	1800				1500			
	INPUT HP	OUTPUT HP	OUTPUT T kgf-m	OUTPUT O.H.L kgf	INPUT HP	OUTPUT HP	OUTPUT T kgf-m	OUTPUT O.H.L kgf
1/200	7.28	4.13	321	1800	6.52	3.63	338	1800
1/300	5.53	2.95	345	1800	4.73	2.46	345	1800
1/400	4.41	2.22	345	1800	3.76	1.84	345	1800
1/500	2.95	1.47	345	1800	3.01	1.48	345	1800
1/600	2.18	1.48	345	1800	2.76	1.23	345	1800
1/800	2.64	1.11	345	1800	2.25	0.92	345	1800
1/900	2.58	0.99	345	1800	2.24	0.83	345	1800

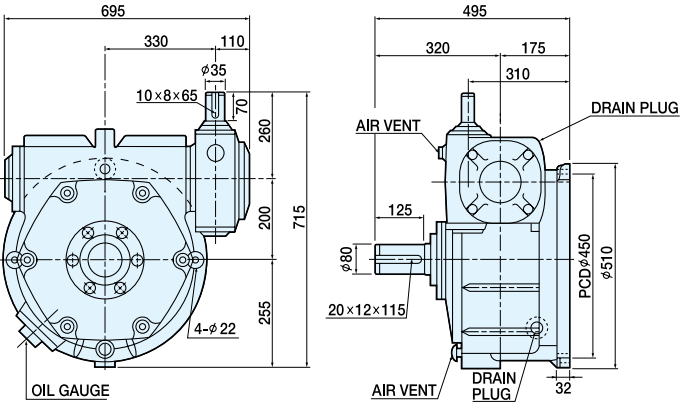
RATIO	1200				900				600			
	INPUT HP	OUTPUT HP	OUTPUT T kgf-m	OUTPUT O.H.L kgf	INPUT HP	OUTPUT HP	OUTPUT T kgf-m	OUTPUT O.H.L kgf	INPUT HP	OUTPUT HP	OUTPUT T kgf-m	OUTPUT O.H.L kgf
1/200	5.45	2.96	345	1800	4.23	2.22	345	1800	2.97	1.48	345	1800
1/300	3.90	1.97	345	1800	3.01	1.47	345	1800	2.14	0.98	345	1800
1/400	3.11	1.48	345	1800	2.43	1.11	345	1800	1.73	0.74	345	1800
1/500	2.48	1.18	345	1800	1.93	0.88	345	1800	1.36	0.59	345	1800
1/600	2.29	0.98	345	1800	1.80	0.74	345	1800	1.28	0.49	345	1800
1/800	2.55	0.74	345	1800	1.46	0.55	345	1800	1.07	0.37	345	1800
1/900	1.87	0.66	345	1800	1.46	0.49	345	1800	1.07	0.33	345	1800

Double Worm Reducer/2단 웜 감속기

MODEL	축배치 및 회전방향	도면	
 <p>DWB-200</p>	A		
	B		
	C		
	D		
	E		
	F		

 <p>DWV-200</p>	A		
	B		
	C		
	D		
	E		
	F		

전동능력표

수치는 1일 8~10시간 연속 운전이고 균일 하중의 수치입니다.

INPUT rpm	1800				1500			
	INPUT HP	OUTPUT HP	OUTPUT T kgf-m	OUTPUT O.H.L kgf	INPUT HP	OUTPUT HP	OUTPUT T kgf-m	OUTPUT O.H.L kgf
1/200	9.80	5.71	454	2200	8.77	5.02	480	2200
1/300	7.39	4.08	488	2200	6.31	3.40	488	2200
1/400	5.76	3.06	488	2200	4.91	2.55	488	2200
1/500	4.76	2.45	488	2200	4.05	2.04	488	2200
1/600	4.24	2.04	488	2200	3.03	1.70	488	2200
1/800	3.33	1.53	488	2200	2.86	1.27	488	2200
1/900	3.26	1.31	488	2200	2.80	1.09	488	2200

INPUT rpm	1200				900				600			
	INPUT HP	OUTPUT HP	OUTPUT T kgf-m	OUTPUT O.H.L kgf	INPUT HP	OUTPUT HP	OUTPUT T kgf-m	OUTPUT O.H.L kgf	INPUT HP	OUTPUT HP	OUTPUT T kgf-m	OUTPUT O.H.L kgf
1/200	7.29	4.08	488	2200	5.66	3.06	488	2200	3.96	2.04	488	2200
1/300	5.20	2.72	488	2200	4.01	2.04	488	2200	2.85	1.36	488	2200
1/400	4.02	2.04	488	2200	3.14	1.53	488	2200	2.22	1.02	488	2200
1/500	3.33	1.63	488	2200	2.59	1.22	488	2200	1.82	0.81	488	2200
1/600	3.02	1.36	488	2200	2.35	1.02	488	2200	1.68	0.68	488	2200
1/800	2.37	1.02	488	2200	1.83	0.76	488	2200	1.66	0.66	488	2200
1/900	2.34	0.87	488	2200	1.21	0.43	488	2200	1.34	0.44	488	2200

MODEL 축배치 및 회전방향 도면

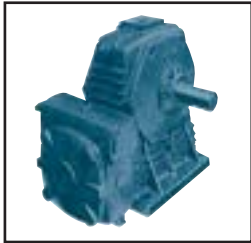

DWB-225

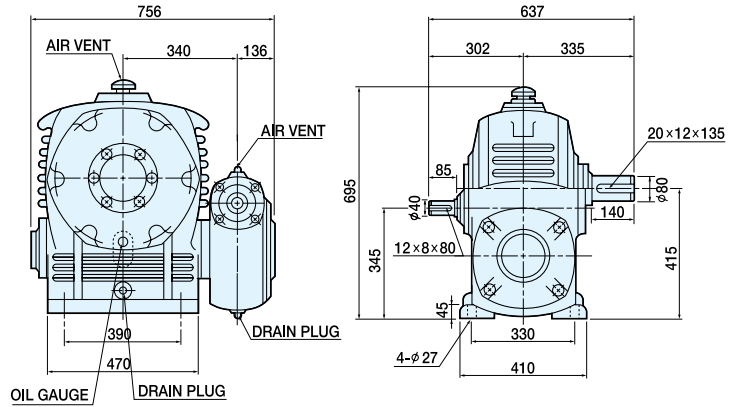
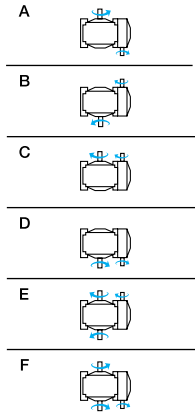

DWV-225

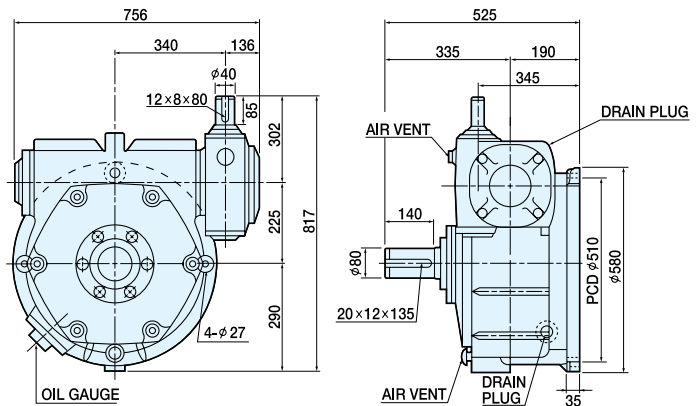
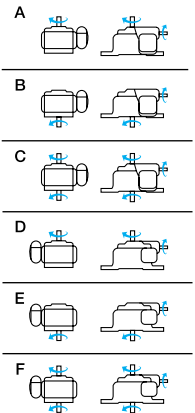

전동능력표

수치는 1일 8~10시간 연속 운전이고 균일 하중의 수치입니다.

INPUT rpm	1800				1500			
	INPUT HP	OUTPUT HP	OUTPUT T kgf-m	OUTPUT O.HL kgf	INPUT HP	OUTPUT HP	OUTPUT T kgf-m	OUTPUT O.HL kgf
1/200	14.30	8.46	650	2500	12.79	7.44	685	2500
1/300	10.70	5.97	690	2500	9.09	4.98	690	2500
1/400	8.03	4.33	690	2500	6.82	3.61	690	2500
1/500	6.62	3.46	690	2500	5.64	2.89	690	2500
1/600	6.15	2.98	690	2500	5.25	2.49	690	2500
1/800	4.67	2.16	690	2500	3.97	1.80	690	2500
1/900	4.71	1.99	690	2500	4.02	1.66	690	2500

INPUT rpm	1200				900				600			
	INPUT HP	OUTPUT HP	OUTPUT T kgf-m	OUTPUT O.HL kgf	INPUT HP	OUTPUT HP	OUTPUT T kgf-m	OUTPUT O.HL kgf	INPUT HP	OUTPUT HP	OUTPUT T kgf-m	OUTPUT O.HL kgf
1/200	10.43	5.99	690	2500	8.14	4.49	690	2500	5.65	2.99	690	2500
1/300	7.43	3.98	690	2500	5.77	2.98	690	2500	4.05	1.99	690	2500
1/400	5.62	2.89	690	2500	4.37	2.16	690	2500	3.08	1.44	690	2500
1/500	4.66	2.31	690	2500	3.62	1.73	690	2500	2.56	1.15	690	2500
1/600	4.31	1.99	690	2500	3.40	1.49	690	2500	2.37	0.99	690	2500
1/800	3.31	1.44	690	2500	2.59	1.08	690	2500	1.84	0.72	690	2500
1/900	3.31	1.32	690	2500	2.63	0.99	690	2500	1.85	0.66	690	2500

Double Worm Reducer/2단 웜 감속기

MODEL 축배치 및 회전방향 도면



DWB-250

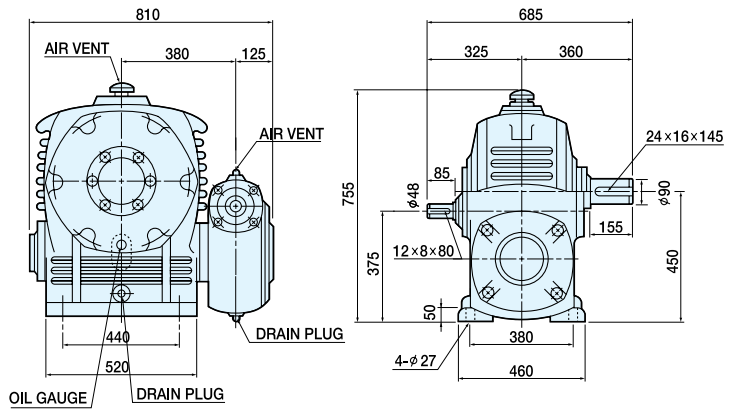
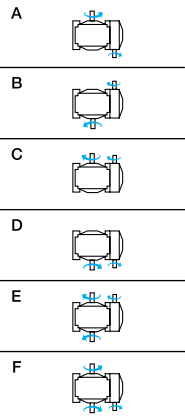

DWV-250

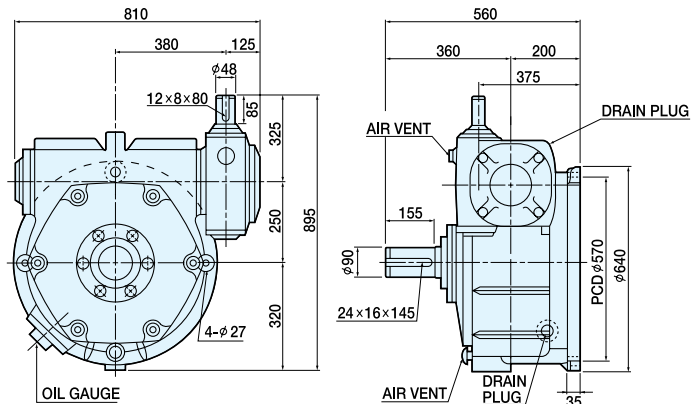
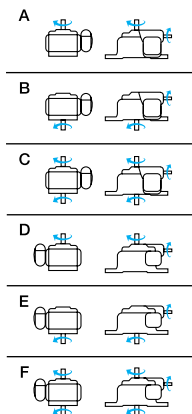

전동능력표

수치는 1일 8~10시간 연속 운전이고 균일 하중의 수치입니다.

INPUT rpm / RATIO	1800				1500			
	INPUT HP	OUTPUT HP	OUTPUT T kgf-m	OUTPUT O.H.L kgf	INPUT HP	OUTPUT HP	OUTPUT T kgf-m	OUTPUT O.H.L kgf
1/200	17.94	10.78	850	2700	15.21	8.99	850	2700
1/300	12.64	7.19	850	2700	10.71	5.99	850	2700
1/400	9.74	5.34	850	2700	8.26	4.45	850	2700
1/500	8.08	4.27	850	2700	6.85	3.56	850	2700
1/600	7.19	3.59	850	2700	5.17	2.52	850	2700
1/800	5.64	2.67	850	2700	4.79	2.22	850	2700
1/900	5.87	2.45	850	2700	5.00	2.04	850	2700

INPUT rpm / RATIO	1200				900				600			
	INPUT HP	OUTPUT HP	OUTPUT T kgf-m	OUTPUT O.H.L kgf	INPUT HP	OUTPUT HP	OUTPUT T kgf-m	OUTPUT O.H.L kgf	INPUT HP	OUTPUT HP	OUTPUT T kgf-m	OUTPUT O.H.L kgf
1/200	12.38	7.19	850	2700	9.59	5.39	850	2700	6.65	3.59	850	2700
1/300	8.76	4.79	850	2700	6.80	3.59	850	2700	4.75	2.39	850	2700
1/400	6.76	3.56	850	2700	5.27	2.67	850	2700	4.93	2.37	850	2700
1/500	5.62	2.84	850	2700	4.40	2.13	850	2700	3.09	1.42	850	2700
1/600	5.03	2.39	850	2700	3.95	1.79	850	2700	2.76	1.19	850	2700
1/800	3.95	1.78	850	2700	3.09	1.33	850	2700	2.18	0.89	850	2700
1/900	4.11	1.63	850	2700	3.27	1.22	850	2700	2.86	0.81	850	2700

MODEL 축배치 및 회전방향 도 면



DWB-300

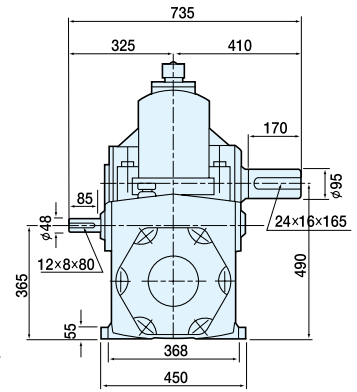
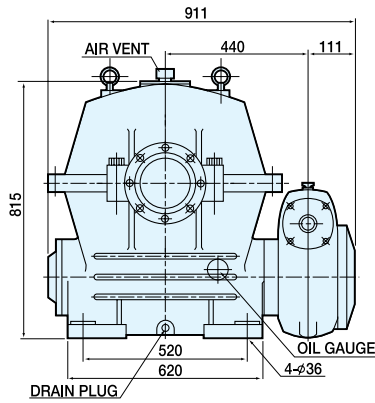
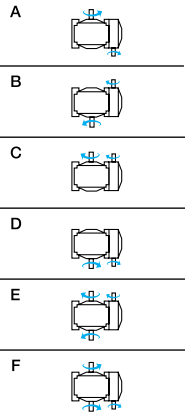

DWV-300

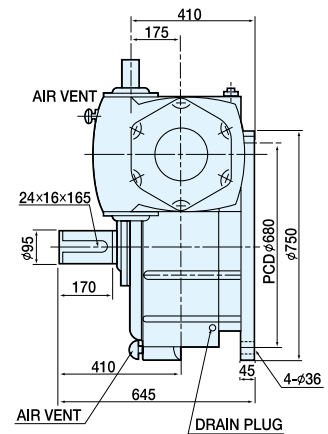
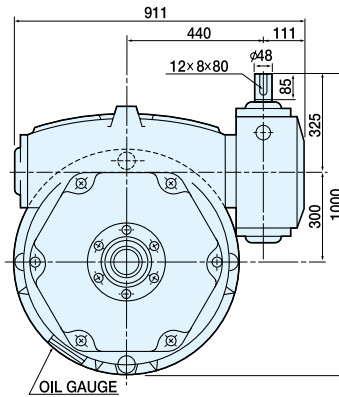
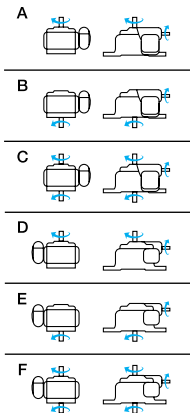

전동능력표

수치는 1일 8~10시간 연속 운전이고 균일 하중의 수치입니다.

RATIO	1800				1500			
	INPUT rpm	INPUT HP	OUTPUT HP	OUTPUT T kgf-m	OUTPUT O.H.L kgf	INPUT HP	OUTPUT HP	OUTPUT T kgf-m
1/200	23.53	14.59	1200	3800	19.93	12.16	1200	3800
1/300	16.60	9.72	1200	3800	14.00	8.10	1200	3800
1/400	13.22	7.53	1200	3800	11.22	6.28	1200	3800
1/500	10.93	6.03	1200	3800	9.26	5.02	1200	3800
1/600	9.42	4.85	1200	3800	7.97	4.05	1200	3800
1/800	7.58	3.76	1200	3800	6.46	3.14	1200	3800
1/900	6.99	3.13	1200	3800	5.93	2.61	1200	3800

RATIO	1200				900				600			
	INPUT rpm	INPUT HP	OUTPUT HP	OUTPUT T kgf-m	OUTPUT O.H.L kgf	INPUT HP	OUTPUT HP	OUTPUT T kgf-m	OUTPUT O.H.L kgf	INPUT HP	OUTPUT HP	OUTPUT T kgf-m
1/300	16.24	9.73	1200	3800	12.50	7.29	1200	3800	8.69	4.86	1200	3800
1/300	11.42	6.48	1200	3800	8.86	4.86	1200	3800	6.18	3.24	1200	3800
1/400	9.15	5.02	1200	3800	7.11	3.76	1200	3800	4.97	2.51	1200	3800
1/500	7.56	4.02	1200	3800	5.91	3.01	1200	3800	4.14	2.01	1200	3800
1/600	6.53	3.24	1200	3800	5.12	2.43	1200	3800	3.59	1.62	1200	3800
1/800	5.29	2.51	1200	3800	4.16	1.88	1200	3800	2.91	1.25	1200	3800
1/900	4.88	2.09	1200	3800	3.86	1.56	1200	3800	2.74	1.04	1200	3800

신축
WORM REDUCER

Double Worm Reducer/2단 웜 감속기

MODEL 축배치 및 회전방향 도 면



DWBM-70

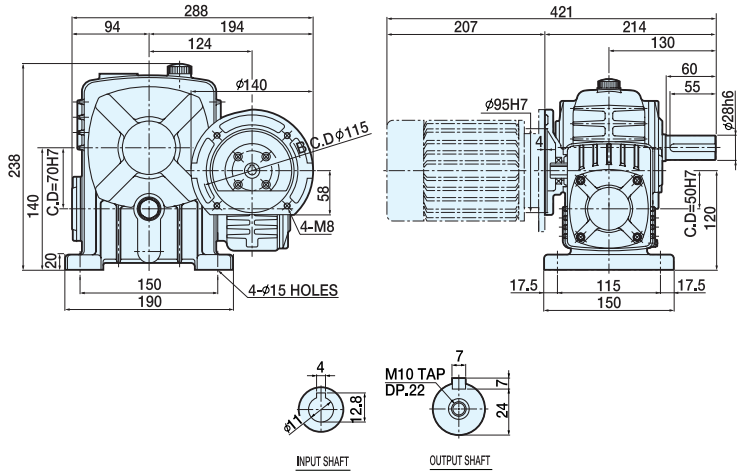
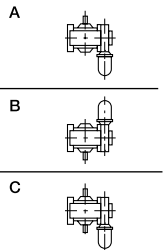

DWVM-70

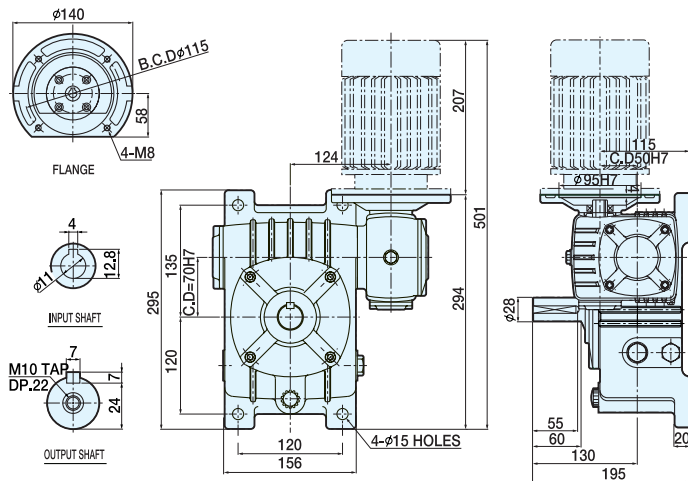
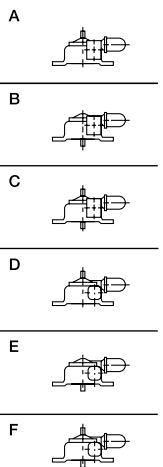

전동능력표 [상기도면은 1/4HP 모터 장착시의 것임]

수치는 1일 8~10시간 연속 운전이고 균일 하중의 수치입니다.

INPUT rpm	1800				1500			
	INPUT HP	OUTPUT HP	OUTPUT T kgf-m	OUTPUT O.H.L kgf	INPUT HP	OUTPUT HP	OUTPUT T kgf-m	OUTPUT O.H.L kgf
1/200	0.15	0.08	5.83	300	0.15	0.07	6.78	300
1/300	0.15	0.09	8.1	300	0.15	0.06	9.14	300
1/400	0.15	0.06	9.69	300	0.15	0.06	11.23	300
1/500	0.14	0.05	11.74	300	0.14	0.05	13.55	300
1/600	0.13	0.05	13.33	300	0.13	0.05	15.37	300
1/800	0.10	0.02	11.16	300	0.08	0.03	12.84	300
1/900	0.10	0.04	16.95	300	0.10	0.04	19.49	300

MODEL 축배치 및 회전방향 도면

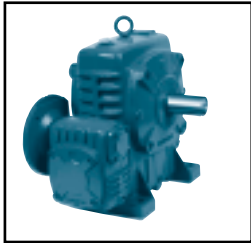

DWBM-80

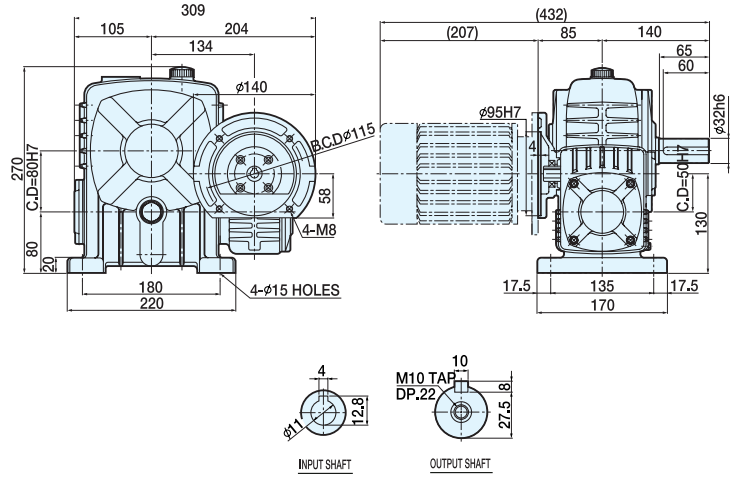
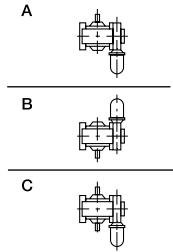

DWVM-80

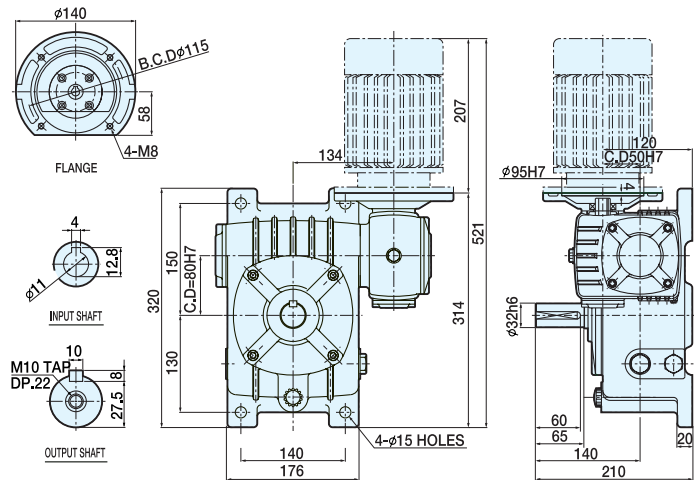
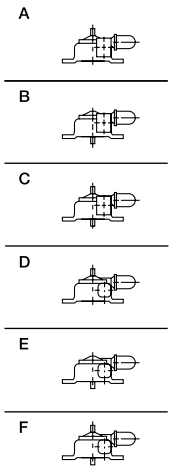



전동능력표

수치는 1일 8~10시간 연속 운전이고 균일 하중의 수치입니다.

INPUT rpm RATIO	1800				1500			
	INPUT HP	OUTPUT HP	OUTPUT T kgf-m	OUTPUT O.H.L kgf	INPUT HP	OUTPUT HP	OUTPUT T kgf-m	OUTPUT O.H.L kgf
1/200	0.25	0.12	9.75	400	0.25	0.11	11.3	400
1/300	0.25	0.11	13.50	400	0.25	0.10	15.59	400
1/400	0.25	0.10	16.05	400	0.23	0.10	18.72	400
1/500	0.23	0.10	19.57	400	0.22	0.09	22.59	400
1/600	0.22	0.09	22.22	400	0.21	0.08	25.62	400
1/800	0.15	0.06	18.60	400	0.18	0.06	21.41	400
1/900	0.20	0.07	28.25	400	0.18	0.07	32.49	400

정신속
WORM REDUCER

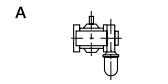
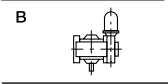
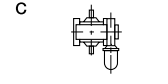
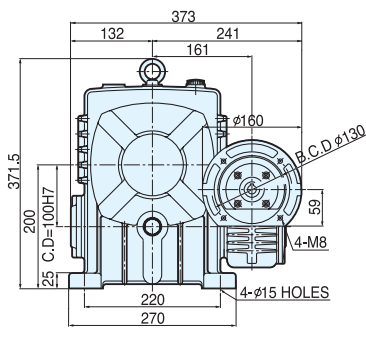
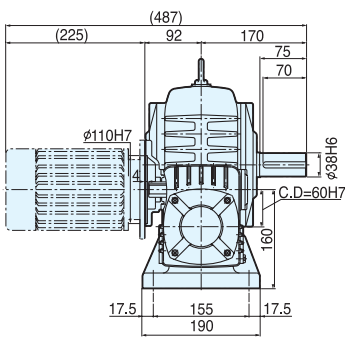
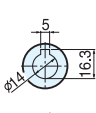
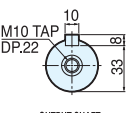
Double Worm Reducer/2단 웜 감속기

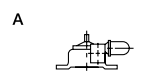
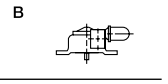
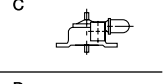
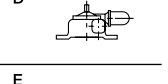
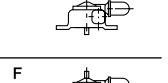
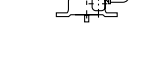
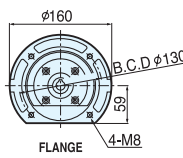
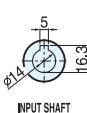
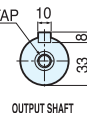
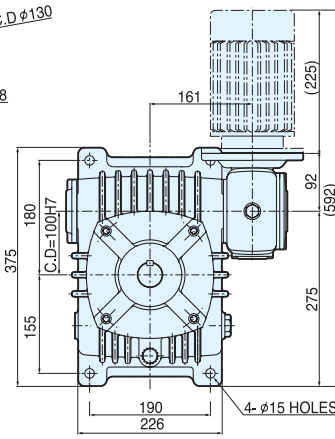
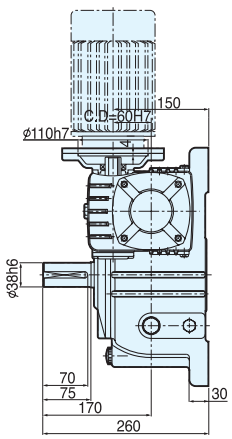
MODEL	축배치 및 회전방향	도	면
 <p>DWBM-100</p>	<p>A</p>  <p>B</p>  <p>C</p> 	   	
 <p>DWVM-100</p>	<p>A</p>  <p>B</p>  <p>C</p>  <p>D</p>  <p>E</p>  <p>F</p> 	    	

전동능력표

수치는 1일 8~10시간 연속 운전이고 균일 하중의 수치입니다.

INPUT rpm	1800				1500			
	INPUT HP	OUTPUT HP	OUTPUT T kgf-m	OUTPUT O.H.L kgf	INPUT HP	OUTPUT HP	OUTPUT T kgf-m	OUTPUT O.H.L kgf
1/200	0.50	0.25	21.23	575	0.50	0.25	24.92	622
1/300	0.50	0.24	29.72	650	0.50	0.24	34.63	650
1/400	0.50	0.23	37.01	650	0.50	0.21	43.16	650
1/500	—	—	—	—	—	—	—	—
1/600	—	—	—	—	—	—	—	—
1/800	—	—	—	—	—	—	—	—
1/900	—	—	—	—	—	—	—	—

MODEL 축배치 및 회전방향 도면



DWBM-120

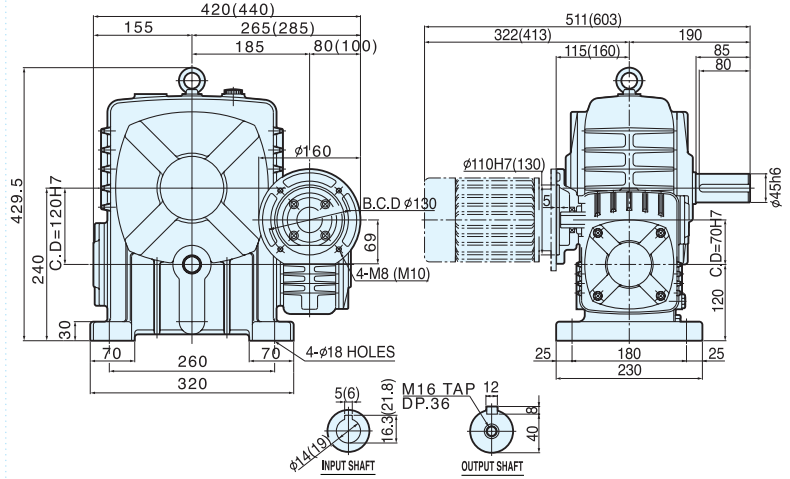
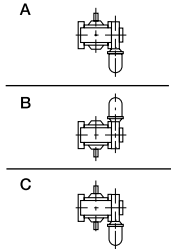

DWVM-120

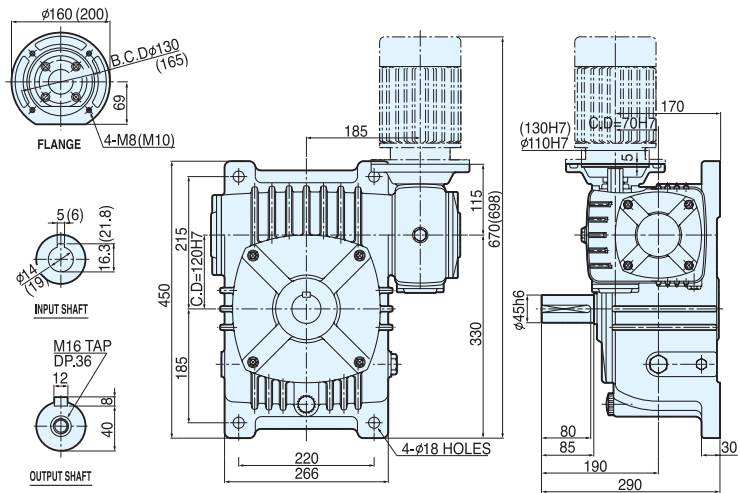
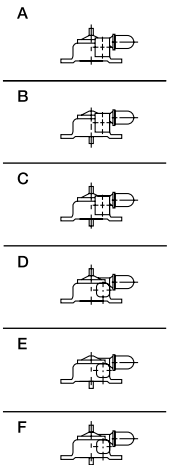



전동능력표

수치는 1일 8~10시간 연속 운전이고 균일 하중의 수치입니다.

RATIO	1800				1500			
	INPUT HP	OUTPUT HP	OUTPUT T kgf-m	OUTPUT O.H.L kgf	INPUT HP	OUTPUT HP	OUTPUT T kgf-m	OUTPUT O.H.L kgf
1/200	1.00	0.51	41.01	618	1.00	0.49	48.16	675
1/300	1.00	0.47	56.77	749	1.00	0.45	66.54	814
1/400	1.00	0.44	72.59	854	1.00	0.44	84.66	925
1/500	0.50	0.20	40.69	942	0.50	0.19	47.17	1000
1/600	0.50	0.19	47.36	1000	0.46	0.19	55.20	1000
1/800	0.43	0.18	57.28	1000	0.46	0.17	64.11	1000
1/900	0.40	0.17	60.64	1000	0.40	0.16	70.43	1000

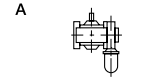
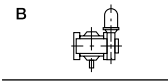
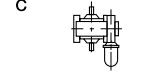
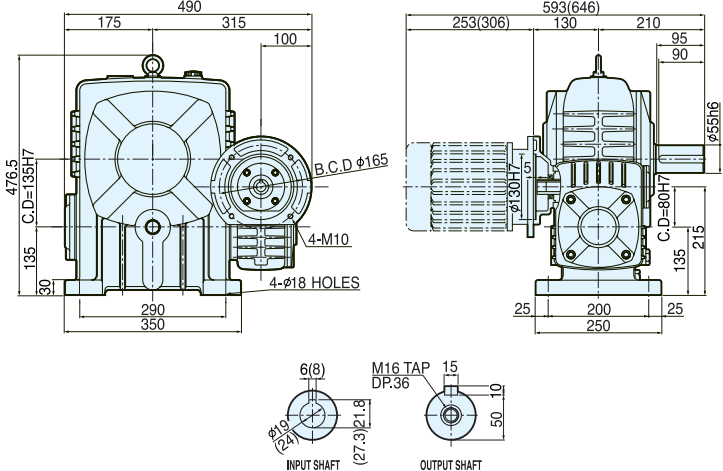
Double Worm Geared Motor / 2단 웜 기어드 모터

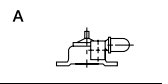
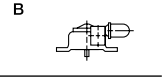
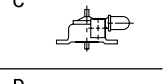
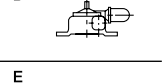
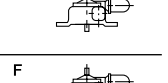
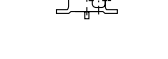
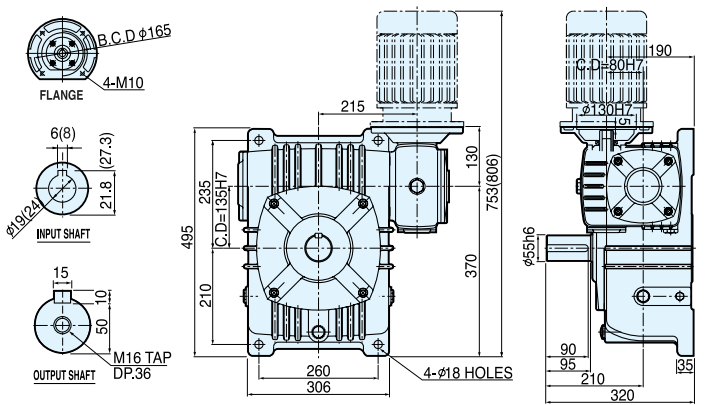
MODEL	축배치 및 회전방향	도면
 <p>DWBM-135</p>	<p>A</p>  <p>B</p>  <p>C</p> 	 <p>Technical drawings for DWBM-135 showing front, side, and shaft views. Dimensions include: 175, 490, 315, 100, 476.5, 135, 30, 290, 350, 4-ϕ18 HOLES, 4-M10, B.C.D ϕ165, 253(306), 593(646), 130, 210, 95, 90, ϕ55H6, 25, 200, 250, 215, 135, 25, 6(8), ϕ19/24, 15, M16 TAP DP.36, 27.3, 21.8, INPUT SHAFT, OUTPUT SHAFT.</p>
 <p>DWVM-135</p>	<p>A</p>  <p>B</p>  <p>C</p>  <p>D</p>  <p>E</p>  <p>F</p> 	 <p>Technical drawings for DWVM-135 showing front, side, and shaft views. Dimensions include: 495, 235, 210, 260, 306, 4-ϕ18 HOLES, 15, M16 TAP DP.36, 50, 10, 27.3, 21.8, ϕ19/24, INPUT SHAFT, 6(8), FLANGE, B.C.D ϕ165, 4-M10, 215, 130, 753(806), 370, 210, 320, 190, C.D=ϕ80H7, ϕ130H7, 90, 95, 210, 135, ϕ55H6.</p>

전동능력표

수치는 1일 8~10시간 연속 운전이고 균일 하중의 수치입니다.

INPUT rpm	1800				1500			
	INPUT HP	OUTPUT HP	OUTPUT T kgf-m	OUTPUT O.H.L kgf	INPUT HP	OUTPUT HP	OUTPUT T kgf-m	OUTPUT O.H.L kgf
1/200	2.00	1.12	89.36	960	2.00	1.09	104.88	1045
1/300	2.00	1.04	124.95	1156	2.00	0.98	140.00	1200
1/400	2.00	0.99	140.00	1200	1.7	0.73	140.00	1200
1/500	1.00	0.47	94.97	1200	1.00	0.45	111.39	1200
1/600	1.00	0.44	106.16	1200	1.00	0.43	124.10	1200
1/800	1.00	0.31	101.82	1200	1.00	0.31	118.48	1200
1/900	1.00	0.36	131.06	1200	1.00	0.35	140.00	1200

MODEL 축배치 및 회전방향 도면



DWBM-155

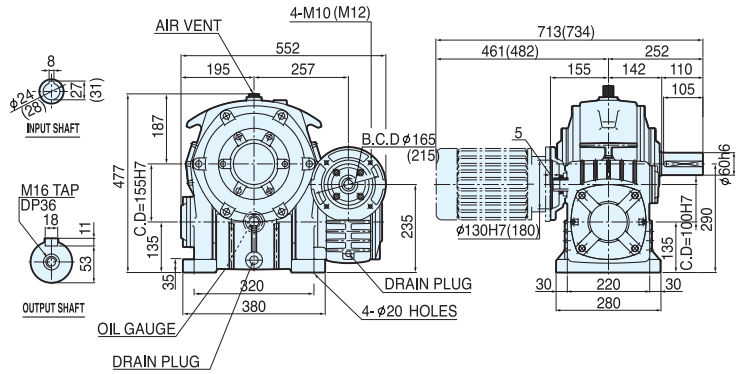
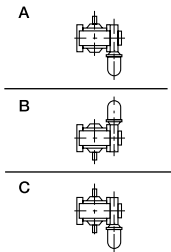

DWVM-155

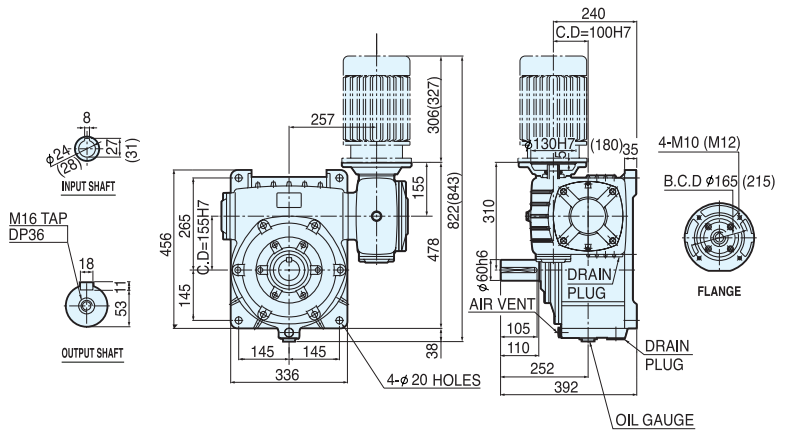
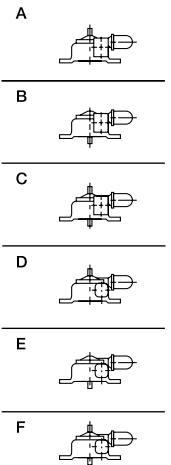

전동능력표

수치는 1일 8~10시간 연속 운전이고 균일 하중의 수치입니다.

RATIO	1800				1500			
	INPUT HP	OUTPUT HP	OUTPUT T kgf-m	OUTPUT O.H.L kgf	INPUT HP	OUTPUT HP	OUTPUT T kgf-m	OUTPUT O.H.L kgf
1/200	3.00	1.66	132.73	1500	3.00	1.63	159.10	1500
1/300	3.00	1.56	187.21	1500	3.00	1.51	217.35	1500
1/400	—	—	—	1500	—	—	—	1500
1/500	2.00	0.96	192.37	1500	2.00	0.94	224.50	1500
1/600	2.00	0.88	211.80	1500	2.00	0.85	242.00	1500
1/800	1.5	0.64	206.45	1500	1.5	0.62	239.95	1500
1/900	1.6	0.70	242.00	1500	1.4	0.58	242.00	1500

Double Worm Geared Motor / 2단 웜 기어드 모터

MODEL 축배치 및 회전방향 도 면



DWBM-175

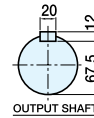
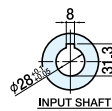
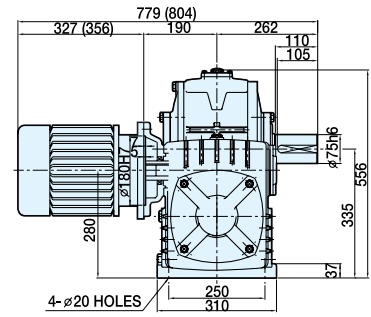
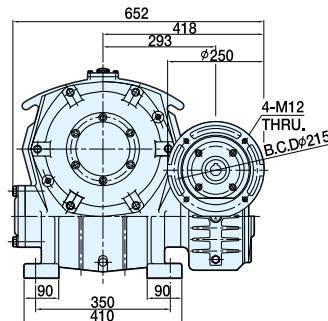
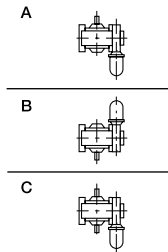

() 안의 치수는 5HP모터 치수임.

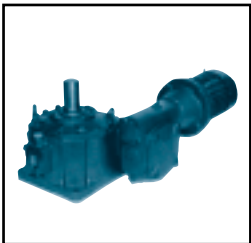

DWVM-175

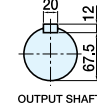
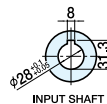
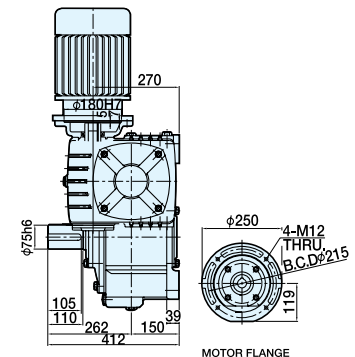
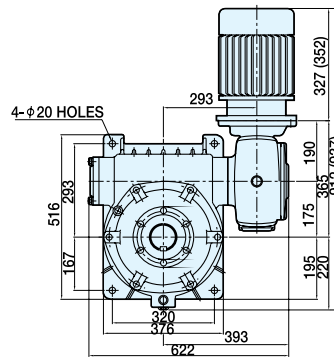
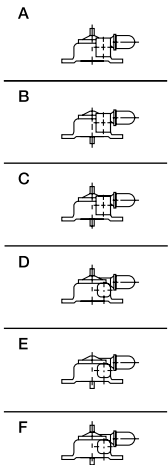

() 안의 치수는 5HP모터 치수임.

전동능력표

수치는 1일 8~10시간 연속 운전이고 균일 하중의 수치입니다.

INPUT rpm	1800				1500			
	INPUT HP	OUTPUT HP	OUTPUT T kgf-m	OUTPUT O.H.L kgf	INPUT HP	OUTPUT HP	OUTPUT T kgf-m	OUTPUT O.H.L kgf
1/200	5.00	2.83	220.17	1800	5.00	2.78	259.34	1800
1/300	—	—	—	1800	—	—	—	1800
1/400	3.00	1.50	234.11	1800	3.00	1.47	274.74	1800
1/500	3.00	1.50	291.95	1800	3.00	1.47	343.21	1800
1/600	3.00	1.37	320.02	1800	2.9	1.23	345	1800
1/800	2.6	1.11	345	1800	2.2	0.92	345	1800
1/900	2.3	0.99	345	1800	2.0	0.83	345	1800

MODEL 축배치 및 회전방향 도면



DWBM-200

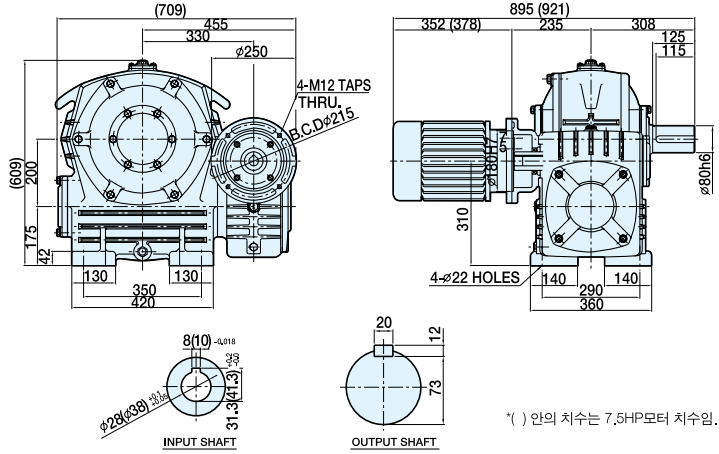
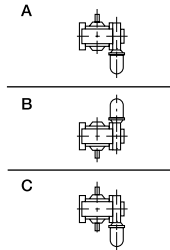

DWVM-200

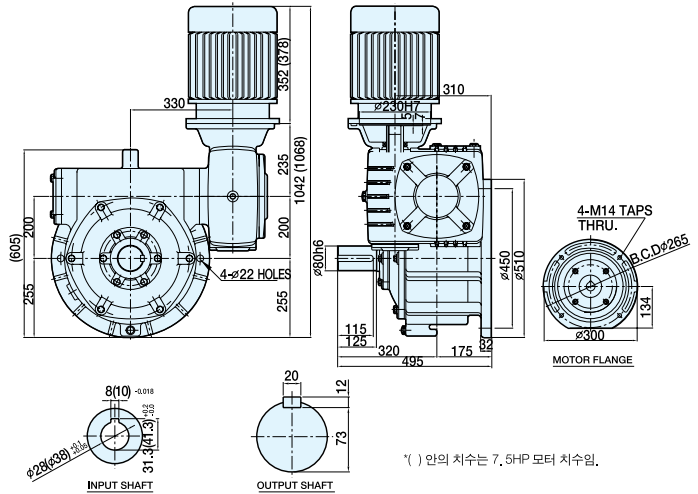
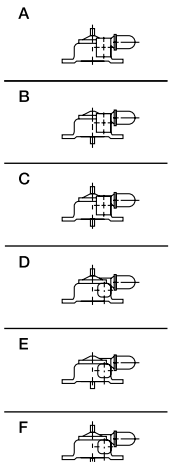

전동능력표

수치는 1일 8~10시간 연속 운전이고 균일 하중의 수치입니다.

RATIO	1800				1500			
	INPUT HP	OUTPUT HP	OUTPUT T kgf-m	OUTPUT O.H.L kgf	INPUT HP	OUTPUT HP	OUTPUT T kgf-m	OUTPUT O.H.L kgf
1/200	7.50	4.36	347.65	2200	7.50	3.16	251.46	2200
1/300	5.00	2.75	329.09	2200	5.00	2.69	385.67	2200
1/400	5.00	2.40	385.67	2200	5.00	2.35	488.00	2200
1/500	5.00	2.45	488.00	2200	4.80	2.04	488.00	2200
1/600	4.80	2.04	488.00	2200	4.00	1.70	488.00	2200
1/800	3.60	1.53	488.00	2200	3.00	1.28	488.00	2200
1/900	3.20	1.36	488.00	2200	2.68	1.14	488.00	2200

정신속
WORM REDUCER

Double Worm Geared Motor / 2단 웜 기어드 모터

MODEL 축배치 및 회전방향 도 면



DWBM-225

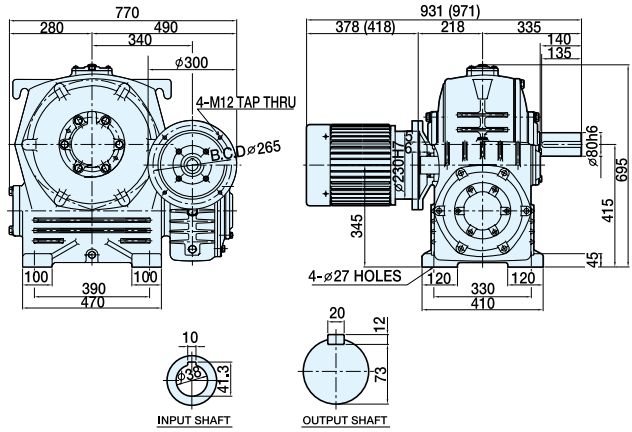
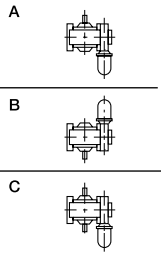

DWVM-225

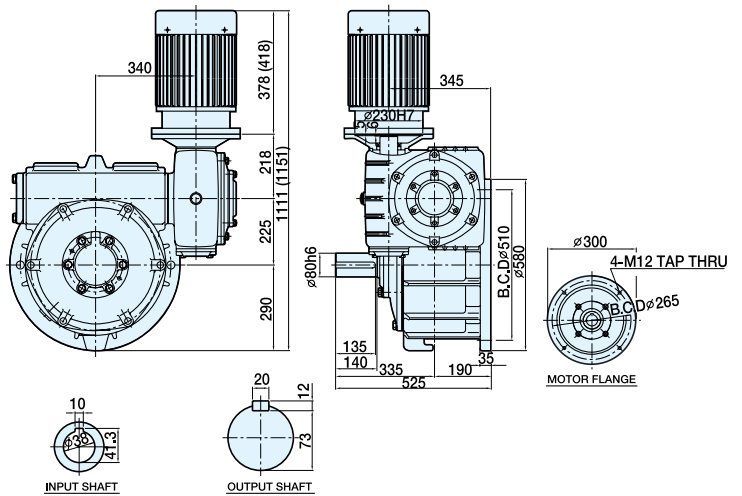
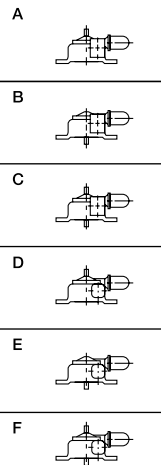

전동능력표

수치는 1일 8~10시간 연속 운전이고 균일 하중의 수치입니다.

INPUT rpm	1800				1500			
	INPUT HP	OUTPUT HP	OUTPUT T kgf-m	OUTPUT O.H.L kgf	INPUT HP	OUTPUT HP	OUTPUT T kgf-m	OUTPUT O.H.L kgf
1/200	—	—	—	2500	—	—	—	2500
1/300	7.50	4.18	482.55	2500	7.50	4.10	568.57	2500
1/400	7.50	4.04	643.02	2500	7.50	3.61	690	2500
1/500	7.50	3.46	690	2500	6.8	2.89	690	2500
1/600	7.00	2.98	690	2500	5.9	2.49	690	2500
1/800	5.00	2.16	690	2500	4.3	1.80	690	2500
1/900	4.70	1.99	690	2500	3.9	1.66	690	2500