

SAMYANG MAX GEARED MOTOR

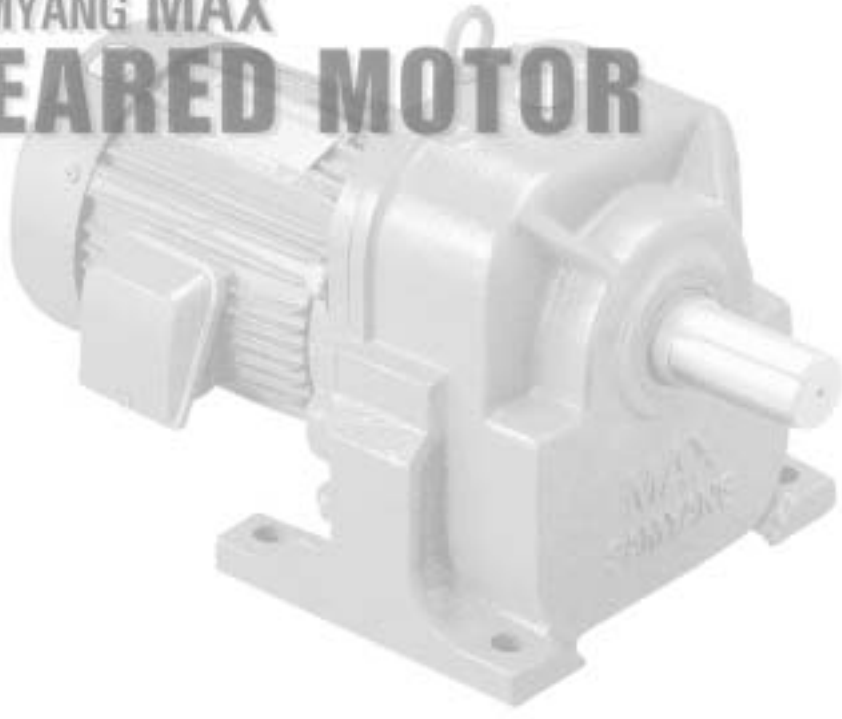

SAMYANG MAX II



형식번호 (Product Code)

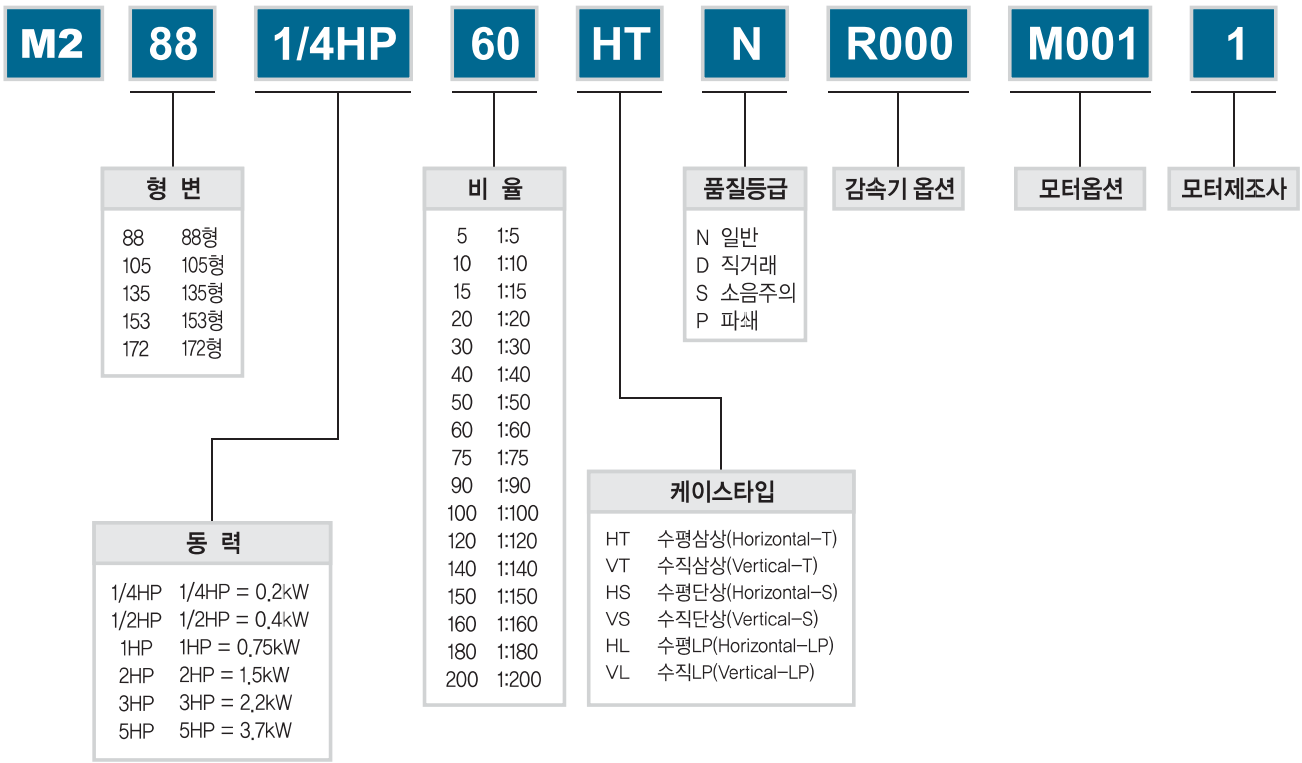

Best Engineered and High Quality MAXII leads the 21st Century

특징

- ▶ **모듈라 시스템**
표준화된 전 부품을 반제품화하여 재고를 확보해 둬므로써
수용가의 어떠한 요구 조건에도 새로이 설계함이 없이 필요부품을
조립하여 신속하게 공급해 드립니다.
- ▶ **제품의 표준화**
최신의 폭넓은 지식과 기술정보를 바탕으로 조립하며, 연결
부분 등 각 부품을 표준화하여 수명이 반영구적이고 또한 경제적
입니다.
- ▶ **고정도, 고효율의 높은 신뢰도**
세이빙, 연마기 등의 최신 정밀기계를 도입하여 제작하므로
고정도, 고효율의 높은 신뢰도를 갖고 있습니다.
- ▶ **소형, 경량**
설계자료를 컴퓨터 처리함으로써 제품이 콤팩트하며, 특수한
열처리와 치형 연마로 소음이 적고 경량이며 고하중을 전달할
수 있습니다.
- ▶ **저렴한 가격**
모든 부품이 표준화에 의한 대량 생산체제를 갖춤으로써 우수한
제품을 저렴한 가격으로 공급하고 있습니다.

Features

- ▶ **Modular System**
All products are well standardized and modularized for
stocking. We can promptly meet any customer's demand
without re-designing the products through assembling
modularized parts.
- ▶ **Product Standardization**
Based on new technology advance and long experience,
we standardize every part such as coupling devices and
make sure of long life and economy of products.
- ▶ **High Precision, High Efficiency and High
Reliability**
Newest high precision machines like shaving and grinding
machine are used to ensure product precision, efficiency
and reliability.
- ▶ **Small Size and Light Weight**
Computer aided design makes product compact. Special
heat treatment and numerical control grinding mach make
noise low and light weight to handle heavy load.
- ▶ **Low Price**
Standardized mass production system lower the cost of
qualified product.

내부구조도
Inside Structure

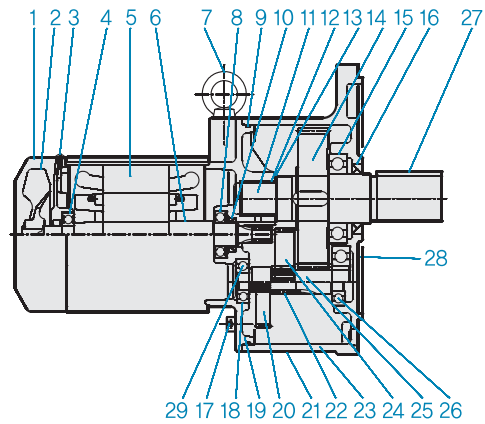
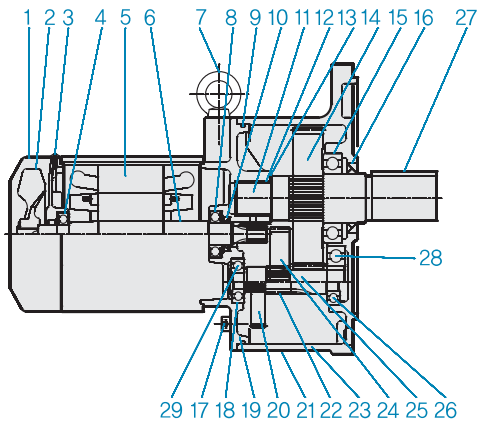
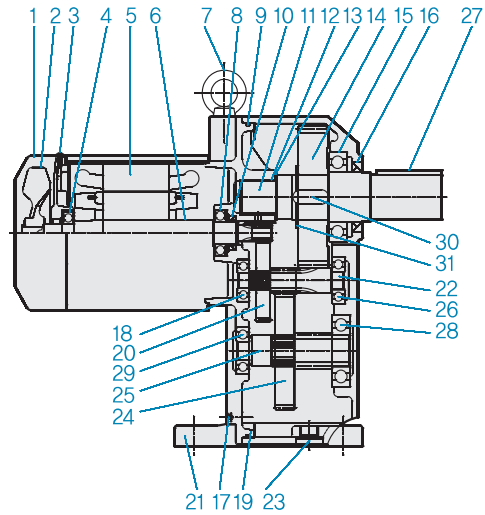
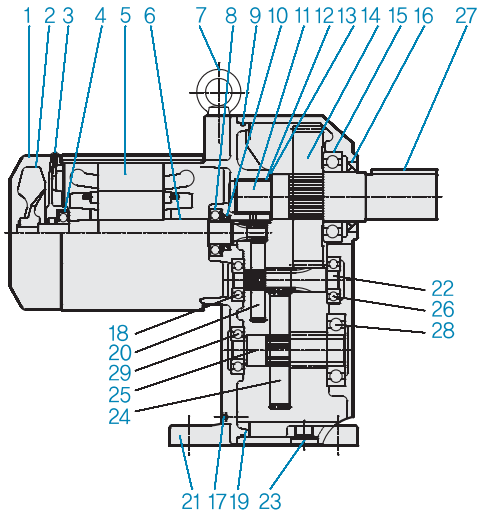

- | | | |
|------------------|-------------------|----------------|
| 1. Fan Cover | 12. DX, DU Bush | 23. Drain Plug |
| 2. Fan | 13. Thrust Washer | 24. Gear C |
| 3. Motor Bolt | 14. Gear A | 25. Pinion B |
| 4. Bearing | 15. Bearing | 26. Bearing |
| 5. Motor Frame | 16. Oil Seal | 27. Key |
| 6. Motor Shaft | 17. Hex Bolt | 28. Bearing |
| 7. Eye Bolt | 18. Bearing | 29. Bearing |
| 8. Bearing | 19. Motor Flange | 30. Key |
| 9. O-Ring | 20. Gear B | 31. Snap Ring |
| 10. Oil Seal | 21. Case | |
| 11. Output Shaft | 22. Pinion A | |

▶ 출력의 선정

- ① 필요한 출력축 회전수 N (RPM)에 따라 감속비를 결정하십시오.
- ② 부하 토크 $T_1(\text{kgf-m})$ 에서 전달토크 $T(\text{kgf-m})$ 를 산출하십시오.

$$T = T_1 \times S_f$$

S_f (서비스 계수) : 출력축에 작용하는 부하의 성질과 운전시간에 의하여 표1에 표시하였습니다.

- ③ 산출된 전달토크 $T(\text{kgf-m})$ 및 부하 토크 $T_1(\text{kgf-m})$ 과 회전수 $N(\text{RPM})$ 에 의하여 그림1의 출력선정도에 의하여 각각의 모터용량을 구하고 가능한 높은 쪽으로 선정하여 주십시오.

(예)

출력수 회전수 : $N = 60\text{RPM}$ (60Hz)

부하토크 : $T_1 = 20 \text{ kgf-m}$

피동기 : 콘베어 (균일하중)

운전시간 : 12시간 / 일

a. 감속비 ϕ : $60/1800 = 1/30$

b. 전달 토크 T : 표2 및 표1에 의하여 $S_f = 1,25$

$$T = T_1 \times S_f = 20 \times 1,25 = 25 (\text{kgf-m})$$

c. 모터출력

부하 토크 T_1 에 의거 $N = 60$ 과 $T_1 = 20$ 의 교차점을 구하십시오.

교차점은 0,75 Kw와 1,5 Kw의 사이

▶ Power Estimation

1. According to required output shaft rotation $N(\text{RPM})$, calculate reduction ratio.
2. Calculate Transfer Load from load torque $T_1(\text{kgf-m})$ by
 $T = T_1 \times S_f$,
 where S_f is service factor. Types of service factor have been classified in Table 2 according to characteristics and operation hours.
3. Using obtained transfer torque T , load torque T_1 and rotation N , choose motor capacity from Tabel 1.
 If possible, choose higher one.

(ex)

Output shaft rotation : $N = 60 \text{ RPM}$ (60Hz)

Load torque $T_1 = 20 \text{ kgf-m}$

Driven Machine : Conveyor

Operation Hours : 12 Hours/day

a. Reduction Ratio ϕ : $60 / 1800 = 1/30$

b. Transfer Torque : T

$S_f = 1.25$ from Table 2 and Table 1

$$T = T_1 \times S_f = 20 \times 1.25 = 25 (\text{kgf-m})$$

c. Motor Output

Point the crosspoint of $T_1 (=20)$ and $N (=60)$.

The crosspoint is between 0.75Kw and 1.5 Kw.

▶ 표1. 서비스 계수 Sf
Service Factor Sf

Load Operation Hr.	U	M	H
3시간 이하/일 (Less 3Hr/Day)	1	1	1.5
3~10시간/일 (3~10Hr/Day)	1	1.25	1.75
10시간 이상/일 (More than 10Hr/Day)	1.25	1.5	2

U : 균일 하중(Uniform Load)
M : 中 정도 충격(Medium Impact)
H : 重 정도 충격(Heavy Impact)

▶ 표2. 피동기계 부하 분류표
Driven Machine

피동기계명(Driven Machine)	부하(Load)	피동기계명(Driven Machine)	부하(Load)
송풍기 Air Blower	U	호이스트 Hoist	M
주조 및 증류장치 Distillation	U	공작기계(주기동) Milling Machine(Main)	M
차량 Car	M	공작기계(보조기동) Milling Machine(Sub)	U
클라리 화이어(정제기) Clarifier	U	금속가공기계 Steel Process Machine	H
선별기 Sorter	M	회전밀 Turning Mill	M
요업기계(중부하) Ceramic Machine(M,Load)	M	턴푸라(텀블링 바렐) Tumbling Barrels	H
요업기계(중부하) Ceramic Machine(H,Load)	H	믹서 Mixer	M
압축기 Compressor	M	유압정제기계 Oil Pressure Cleaner	M
콘베아(균일부하) Conveyor(Uniform)	U	제지기계 Paper Machine	M
콘베아(불균일부하) Conveyor(Non-uniform)	M	제재기계 Wood Cutter	H
크레인 Crane	U	펌프 Pump	M
크랏샤 Crusher	H	고무기계(중부하) Rubber Machine(M,Load)	M
준설용선박(중부하) Drainage(M,Load)	M	고무기계(중부하) Rubber Machine(H,Load)	H
준설용선박(중부하) Drainage(H,Load)	H	수처리기계(중부하) Water Cleaner(L,Load)	U
엘리베이터 Elevator	U	수처리기계(중부하) Water Cleaner(H,Load)	M
압출기 Extruder	U	스크린(유체) Screen(Oil Based)	U
팬 Fan	U	제당기계 Sugar Machine	M
공급기 Supplier	M	섬유기계 Textile Machine	M
공급기(왕복동식) Supplier(Commuting)	H	제철기계(열간) Iron Works(Heat Treat)	H
식품기계 Food Machine	M	제철기계(냉간) Iron Works(Cold Treat)	U
햄머밀 Hammer Mill	H		

▶ 그림1. 출력의 선정
Output Estimation Chart

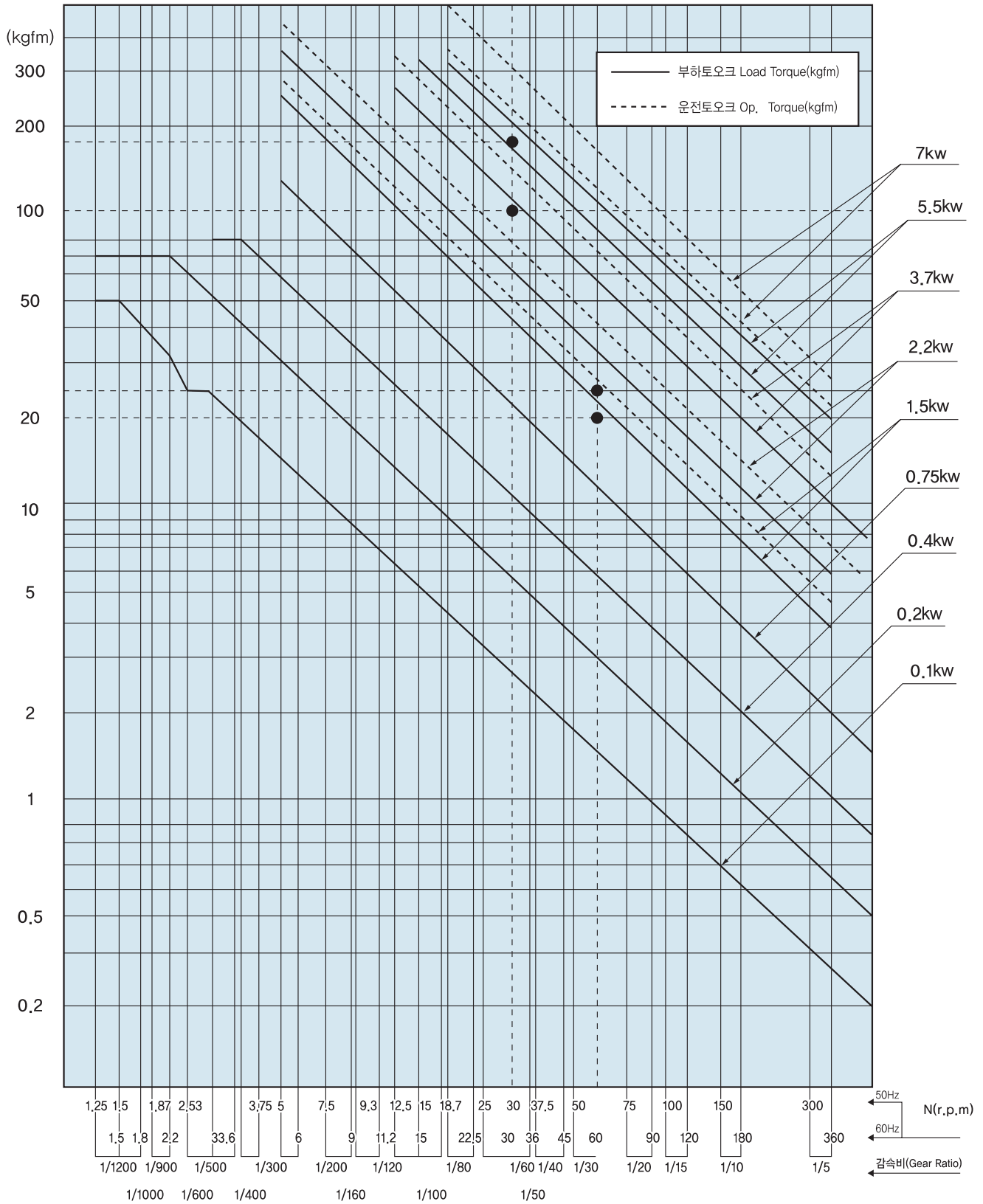

➔ O.H.L (Overhang Load) 의 확인

O.H.L은 출력축에 작용하는 굽힘하중의 위치를 표시하고 있습니다. 상대기계와 체인, 기어, 벨트 등으로 연결한 경우에 발생하며, 카프링에 의한 직결의 경우에는 발생치 않습니다.

O.H.L(kgf) = $T_1 / R \times S_f \times E_f \times L_f \times 1000$
 T_1 (kg-m) : 사용 토크
 R(mm) : 스프로켓, 기어, 풀리 등의 피치원반경
 E_f : 연결방법에 따른 E_f 값 (표3에서 구함)
 L_f : 작용거리에 따른 L_f 값 (표4에서 구함)

산출한 O.H.L은 사용 기어드 모터의 허용 O.H.L의 이하에서 R 및 L_f 를 결정하여 주십시오.
 허용 O.H.L은 규격별로 표시되어 있습니다.

➔ 플라이 휠 효과

부하의 관성(GD^2)이 크거나 단속운전을 할 때 시동시 (또는 브레이크에 의한 제동시)에 간헐적으로 커다란 토크가 발생할 경우에 고장의 원인이 될 수가 있으므로 그림3에 의한 부하의 관성과 허용시동 회수를 확인하여 주십시오.

모타축환산부하 $GD^2(GD^2\ell) =$
 출력축환산 $GD^2 \times (\text{속비})^2$
 $GD^2\text{비}(R) = \frac{\text{모타축환산부하}GD^2(GD^2\ell)}{\text{기어드모터의 } GD^2(GD^2_M)}$
 GD^2_M : (19페이지 참조)

그림 2 (Figure 2)

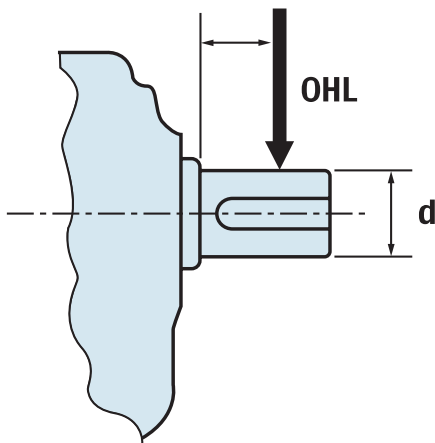

➔ Overhang Load

Overhang load indicates the position of side force occurred on output shaft. Overhang load is typically occurred when the motor has been coupled through chain, gear or belt and so forth. Direct coupling does not cause overhang load.

O.H.L(kgf) = $T_1 \times S_f \times E_f \times L_f \times 1000$
 T_1 (kg-m) : Applied Torque
 R(mm) : Diameter of pitch in sprocket, gear or pulley
 E_f : E_f value according coupling method (Refer Table 3)
 L_f : L_f value according operation distance (Refer Table 4)

Obtained OHL should be lower than allowed OHL of selected gear motor, and R and L_f is obtained from the obtained OHL value. Allowed OHL is enlisted according to types.

➔ Fly Wheel Effect

When load inertia(GD^2) is high or the motor is intermittently operated, momentarily occurred heavy torque may cause the reason of breakdown. Please make sure of load inertia and allowable starting number from Picture 3.

Motor Shaft Conversion Load Inertia ($GD^2\ell$) =
 Output Shaft Conversion Inertia x (Reduction Ratio)²
 where,
 Inertia Ratio(R)=Motor Shaft Conversion Load Inertia ($GD^2\ell$) / Geared Motor Inertia (GD^2_M)
 For GD^2_M , refer data table in page 11.

Using obtained R and Figure 3, one can get allowable starting total number.

▶ 표3. 연결방법 Coupling Ef

단열체인 (Single Row Chain)	1.00
타이밍 벨트(Timing Belt)	1.00
복열체인 (Double Row Chain)	1.25
기어 (Gear)	1.25
벨트 (V-Belt)	1.50
평벨트 (Plain Belt)	2.50

R 수치와 그림3에 의한 허용시동 총회수를 얻을 수 있습니다.

(예) 모터출력 : 5.5 kw 연결방법 : 체인
속 비 : 1/10 기동정도 : 20 sw/h
부하 GD²(출력축환산) : 4.8 kg · m²

1) $GD^2\ell = 4.8 \times (1/10)^2 = 0.048 \text{Kg} \cdot \text{m}^2$

2) $R = \frac{GD^2\ell}{GD^2} = \frac{0.048}{0.12} = 0.4$

3) 그림 3에 의한 R = 0.4 의 수직선 체인의 선과 교점을 구하고 그점에 의한 수평선과 5.5Kw 선의 교점이 허용시동 총회수로 3 × 10⁵ 회수가 됩니다.

4) 내구시간은 $\frac{\text{허용시동총회수}}{\text{기동정도}} = \frac{3 \times 10^5}{20} = 15,000 \text{시간}$

▶ 표4. 작용위치 Applied Point Lf

ℓ	Lf
0.25d	0.85
0.50d	0.90
0.75d	0.95
1.00d	1.00
1.25d	1.25
1.25d	1.50

(ex)

Motor Output : 5.5 kw, Reduction Ratio : 1/10
Load Inertia(Output shaft Conversion) : 4.8 kg · m²
Coupling Method : Chain, Starting Coefficient : 20sw/h

1) $GD^2\ell = 4.8 \times (1/10)^2 = 0.048 \text{Kg} \cdot \text{m}^2$

2) $R = \frac{GD^2\ell}{GD^2} = \frac{0.048}{0.12} = 0.4$



3) In Picture 3, find the crosspoint(A) of R = 0.5 and the curve of chain. Then the allowable starting total number is the crosspoint between horizontal line from(A) and the required power 5.5 Kw. In this example the allowable starting total number becomes 3 × 10⁵.

4) Durable hours : Allowable starting total number / Starting Coefficient = 3 × 10⁵/20 = 15,000 hours

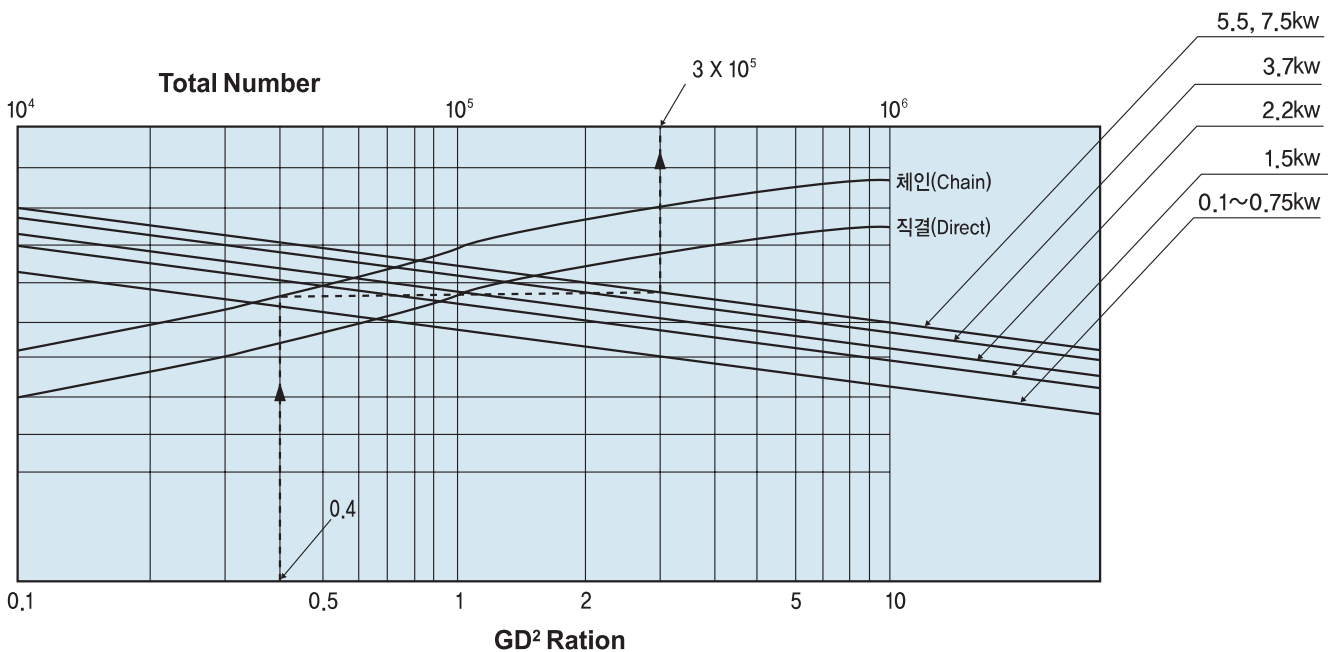
그림 3 허용시동 총회수 (Allowable Starting Total No.)



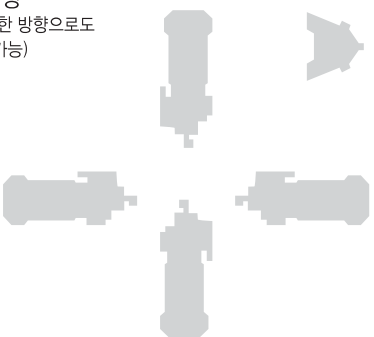
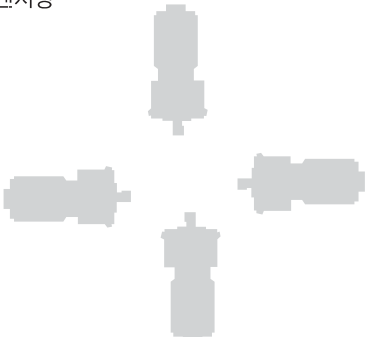
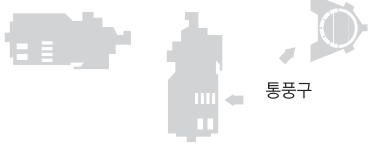

기어 모터 형식별 설치방향

형식	윤활	H형	V형
MAX-H 3상	그리스	수평형 (어떠한 방향으로도 설치가능) 	플랜지형 
MAX-H 단상	그리스	 통풍구 (그림과 같은방향으로 설치가능)	 통풍구

- ▶ 그리스 윤활의 경우는 위와 같이 자유롭게 설치할 수 있음.
- ▶ 브레이크 부착형 기어 모터의 경우 세워서 설치할 경우 슬립발생을 주의

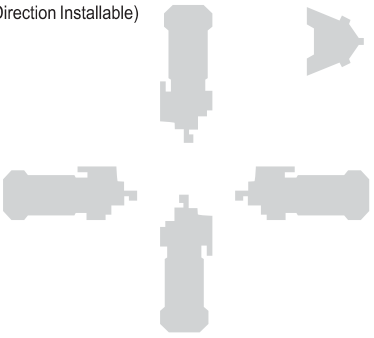
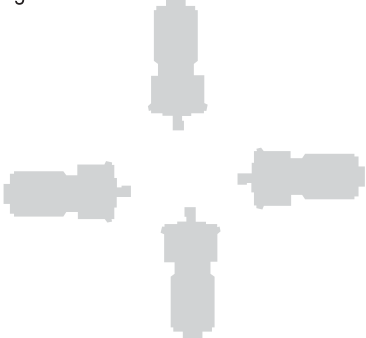
GEARED MOTOR INSTALLATION

Type	Lubricant	H Type	V Type
MAX-H 3-Phase	Grease	Horizontal (Any Direction Installable) 	Flange 
MAX-H 1-Phase	Grease	 Vent (Specified Direction Only)	 Vent

- ▶ Grease charged motor can be installed for any direction.
- ▶ Caution is necessary for geared motor with brake to be installed vertically in order to prevent slip.

기어드 모터 규격별 그리이스 주입량 (Grease Charging Quantity)

	5~30	40~75	90~200
0.2kw	0.1	0.42	0.7
0.4kw	0.2	0.7	1.5
0.75kw	0.7	0.95	1.65
1.5kw	1.2	1.9	2.3
2.2kw	2.5	2.8	-
3.7kw	3.8	-	-

- 공장 출하시에 0.2 ~ 3.7 Kw의 전기중에 그리이스를 충전하여 출하하고 있습니다.
- 그리이스의 교환시기는 2,000시간마다 교환하여 주십시오.
- 그리이스 교환시 양은 상기표를 참조 하십시오.

- Geared motors powered between 0.2 and 3.7 Kw are charged with grease during factory shipment.
- Grease should be replaced at every 2,000 hours.

기어드 모터의 GD²M (모터축 환산) Geared Motor GD²M (Motor Shaft Conversion)

kw	4p	
	일반형 General	브레이크 부착 With Brake
0.2	0.0028	0.0035
0.4	0.0056	0.0069
0.75	0.0099	0.0112
1.5	0.0271	0.0321
2.2	0.0301	0.0351
3.7	0.0456	0.0506

MAXII - GM 소음 수준 MAXII Geared Motor Noise Level

Geared Ratio		5	10	15	20	30	40	50	60	75	90	100	120~200
RPM		360	180	120	90	60	45	36	30	24	20	18	15~9
(kw) 출력	0.2	62	62	62	61	61	61	61	61	61	61	61	60
	0.4	62	62	62	61	61	61	61	61	61	61	61	60
	0.75	64	64	64	63	63	63	63	63	63	63	63	62
Out put	1.5	70	70	70	68	68	68	68	68	68	68	68	67
	2.2	70	70	70	68	68	68	68	68	68	68	68	67
	3.7	70	70	70	68	68	68	68	68	68	68	68	67

삼상유도 전동기 참고 특성 DATA

Three Phase Induction Motor Reference Characteristic Data

출력 KW(HP)	극수 Pole	정격전류 Regular Current		기동전류 Starting current		효율 Efficiency %	역율 Power Factor %	전부하 Total Load Torque (kg-m)	Slip %	R.P.M
		220V	380V	220V	380V					
0.2 (1/4)	4	1.3	0.8	5.5	3.2	61	60	0.11	9.5	1638
0.4 (1/2)	4	2.2	1.3	11.3	6.5	65	64	0.22	9.0	1638
0.75 (1)	4	3.6	2	21	12.2	72	71	0.42	8.0	1656
1.5 (2)	4	6.3	3.6	36	21	78	78	0.85	7.5	1674
2.2 (3)	4	8.8	5.1	54	33	81	79	1.23	7.0	1674
3.7 (5)	4	13.7	7.9	95	55	83	80	2.06	6.5	1683

GEARED
MOTORS

특징

- a) 무여자 작동형 (스프링 크로스식)으로서 정전시에는 자동적으로 작동하는 안전 브레이크입니다.
- b) 전원장치가 있어 배선이 용이합니다.
- c) 간단한 구조로 브레이크 갭 조정도 용이합니다.

Features

- a) Cross spring type geared motor is automatically operational event at power failure.
- b) Power connector makes easy wiring.
- c) Simple structure makes brake gap adjustment easy.

브레이크 사양

Brake specification

사양 Spec.	출력 Output(KW) 4p						
	0.2	0.4	0.75	1.5	2.2	3.7	
브레이크 Brake	SB-1.0	SB-1.0	SB-2.0	SB-3.0	SB-6.0	SB-8.0	
토크 Torque (kg · m)	1.0	1.0	2.0	3.0	3.5	8	
전원장치 Power Supplier	HD - 20B						
전압 Voltage	AC 200V (DC 90V)						
전류 Current at 75°C (A)	0.27	0.27	0.25	0.27	0.3	0.4	
용량 Capacity at 75°C(W)	24	24	22	24	27	36	
규정 틈새 Regular Gap (mm)	0.3						
한계 틈새 Limit Gap (mm)	0.8						
허용별 열발산량 Allowable Heat Dissipation at 1500R,P,M 50% ED(kgf,m/min)	500	500	600	800	800	1100	
총사사양 E,T (kgf · m)	2.2 X 10 ⁷	2.2 X 10 ⁷	3.6 X 10 ⁷	4.5 X 10 ⁷	4.5 X 10 ⁷	6.3 X 10 ⁷	
개방시간 Amateur Release Time(sec)	동시절환 AC/DC Converting	0.225	0.205	0.298	0.150	0.135	0.230
	교류절환 AC Converting	0.130	0.075	0.120	0.054	0.050	0.070
	직류절환 DC Converting	0.023	0.012	0.013	-	-	-

브레이크의 구조
Brake Structure

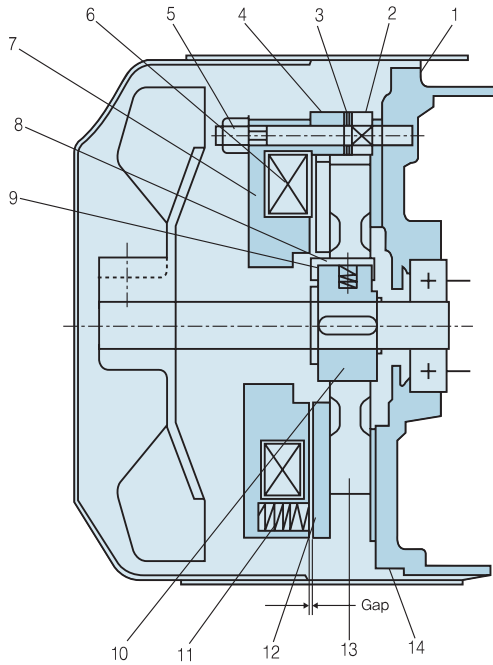

SB-1.0~8.0

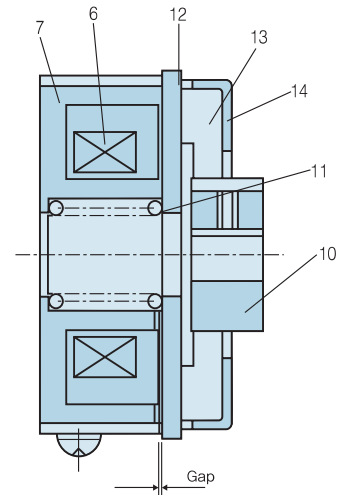

SB-0.2

명칭	NO.	Name
브라켓 실드	1	Bracket shield
스터드 볼트	2	Stud Bolt
어드저스트 라이너	3	Adjust Liner
칼라	4	Collar
육각 너트	5	Hex - Nut
코일	6	Coil
자석	7	Magnet
소음 브라켓	8	Sound Bracket
소음 스프링	9	Sound Spring
호브	10	Hob
브레이크 스프링	11	Brake Spring
아마츄어	12	Armature
내부 디스크	13	Inner Disk
브라켓	14	Bracket

▶ GD²플라이 휠의 효과 계산법 Calculation of Fly Wheel Inertia GD²

관성을 일반적인 관성모멘트 ℓ (Kg · m · sec²)로 나타내고 있습니다만 공업용으로 실제 사용할 경우는 GD²(Kg-m²)을 사용하는 것이 편리하다.

In general, inertia is represented by inertia momentum (Kg.m.sec²), however, GD² is more widely used for industrial purpose.

$$GD^2 = 4g\ell \quad \text{여기서}$$

{	G -----	중량 Weight(Kg)
	D -----	회전직경 Rotation Diameter (m)
	g -----	중력가속도 Gravity (9.8 m/sec ²)
	ℓ -----	관성모멘트 Inertia Momentum (Kg.m.sec ²)

▶ 회전체의 GD² Inertia of Gyration Object

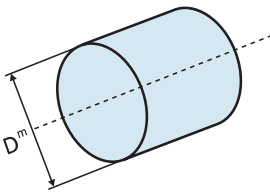
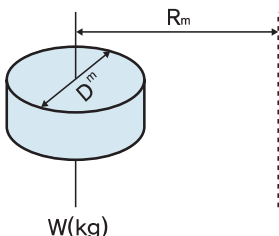
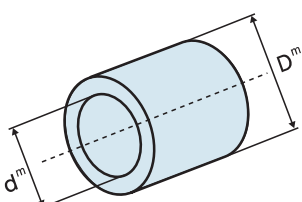
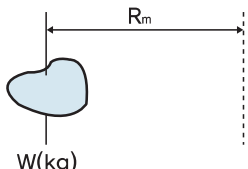
회전중심이 무게중심과 일치할 때 Rotation Center = Gravity Center		회전중심이 무게중심과 일치하지 않을 때 Rotation Center ≠ Gravity Center	
 W(kg)	$GD^2 = \frac{1}{2}WD^2_M$ (Kg . m ²)	 W(kg)	$GD^2 = \frac{1}{2}WD^2_M + 4WR^2_M$ (Kg . m ²)
 W(kg)	$GD^2 = \frac{1}{2}W(D^2_M + d^2_M)$ (Kg . m ²)	 W(kg)	$GD^2 = 4WR^2_M$ (Kg . m ²)

➔ 직선운동을 하는 경우의 GD²
Inertia of Straightly Moving Object

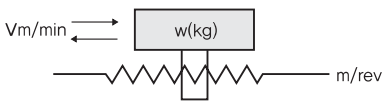
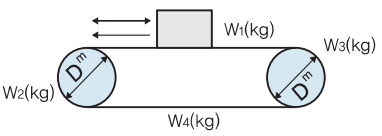
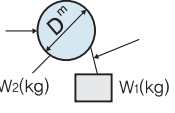
<p>일반적인 경우 General Case</p>		$GD^2 = W \cdot \left(\frac{V}{\pi n} \right)^2 \quad (\text{kg} \cdot \text{m}^2)$
<p>수평직선 운동인 경우 Horizontal Straight Movement (리드스크류에 의한 물체의 이동) (Moved by Lead Screw)</p>		$GD^2 = W \cdot \left(\frac{P}{\pi} \right)^2$ $= W \cdot \left(\frac{V}{\pi n} \right)^2 \quad (\text{kg} \cdot \text{m}^2)$
<p>수평직선 운동인 경우 Horizontal Straight Movement (콘베어 등) (Conveyor...)</p>		$GD^2 = W_1 D_m^2 + 1/2 W_2 D_m^2 + 1/2 W_3 D_m^2 + W_4 D_m^2 \quad (\text{kg} \cdot \text{m}^2)$
<p>수직 운동인 경우 Vertical Straight Movement (크레인, 윈치 등) (Crane, Winch...)</p>		$GD^2 = W_1 D_m^2 + 1/2 W_2 D_m^2 \quad (\text{kg} \cdot \text{m}^2)$

➔ 회전비가 있는 경우의 GD²
Inertia with Rotation Ratio

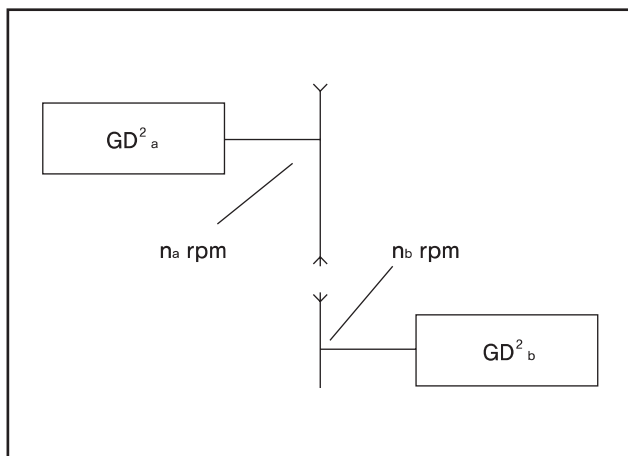

부하측의 GD²_b를 n_a축에 환산할 경우
Conversion of load shaft inertia to n_a shaft
 $GD^2 = GD^2_a + (n_b/n_a)^2 GD^2_b$

▶ 설치 및 사용상 주의사항

1. 설치전의 점검

감속기는 당공장에서 철저한 검사 및 점검한 후 납품하지만, 수송 도중 진동이나 그외 악영향을 받는 경우가 있으므로 설치 전에 반드시 다음 사항을 점검하십시오.

- ① 누유되는 곳은 없는가 ② 파손된 부분은 없는가 ③ 명판은 주문 사항과 일치하는가

2. 상대기계와 연결 방식

1) 직결방식

입출력축 모두 직결방식을 사용하는 것이 가장 좋으며 커플링은 가급적 가요성 커플링을 사용하시기 바랍니다.

2) 기어, 체인 스프로킷 사용시

- 입출력축에 체인, 스프로킷, 풀리 등을 취부하는 경우 아래의 공식에 의해서 스프로킷 및 기어의 직경을 선정해 주십시오.
체인스프로킷 기어의 피치원 직경 $\geq 3 \times$ 입출력축의 직경
- 입출력축의 선단에 하중이 작용하면 축에 무리한 힘이 걸려서 축이 파괴되거나 베어링이 손상될 우려가 있으므로 완전히 안쪽(카바쪽)으로 조립한 후 사용하십시오.

3. 윤활유의 선정 및 보존

1) 주유 및 유량

윤활유는 반드시 추천 윤활유를 사용하고 유량은 완전 정지상태에서 유면계의 중심까지 오게 하십시오. 윤활유가 너무 많거나 적으면 기어와 베어링에 악영향을 미칠 우려가 있습니다.

2) 윤활유의 교환

처음 가동시에는 기어의 초기 마모분이 기름에 떨어지므로 운전개시 후 500시간 정도 사용후 새로운 윤활유로 교환하여 사용하고 그 후는 매 2000시간마다 교환하여 주십시오.
윤활유 교환시 내부를 깨끗하게 세척하여 마모분을 제거하십시오.

▶ Gaudions during Installation and Use

1. Before Installation

Products get through inspection prior to shipment, however, vibration during delivery or other improper treatment may cause problem. Please make sure of following check point prior to installation.

- (1) Oil Leakage (2) Cracks (3) Order Specification

2. Coupling Method with Machine

(1) Direct Coupling : Direct coupling is the best for both input and output shaft coupling.

(2) Use with Gear, Sprocket or Chain

- When gear, sprocket or chain is connected with input or output shaft, please determine the diameter of sprocket or gear using following equation.
- If load is given to shaft end, excessive force harms to bearing and other parts. Make sure of coupling machine to deep side of shaft.

3. Grease

(1) Charging and Quantity : One should use only recommended grease, and charge grease up to the center of oil gauge at fully stoped mode. Both more and less grease may cause problems to gear and bearing.

(2) Grease Change : For the first 500 hour run, there are excessive particles in grease. Hereafter, grease can be replaced at every 2,000 hours. Rinse inside to remove particles during grease change.

➡ 추천 윤활유

Recommended Lubricant

Type	Maker	호남정유 Honam Ref. CALTEX	유 공 Yukong GULF	극 동 Kuk Dong SHELL	MOBIL KOREA
그리스 Grease	NLGI 0	Multifak EP 0	Crown EP 0	Alvania EP 0	Mobilplex EP 0
	NLGI 1	Multifak EP 1	Crown EP 1	Alvania EP 1	Mobilplex EP 1
	NLGI 2	Multifak EP 2	Crown EP 1	Alvania EP 2	Mobilplex E 2

- 그리스 전용 기어드모터에는 NLGI 0 을 사용하십시오.
- 주위온도가 40℃ 이상되는 경우에는 당사에 문의하여 주십시오.
- Greased motor needs to use NLGI 0.
- For use of motor at higher than 40℃, Please ask us for direction.

▶ 삼상 I.E.C 플랜지 모터
3-Phase I.E.C Flange Motor

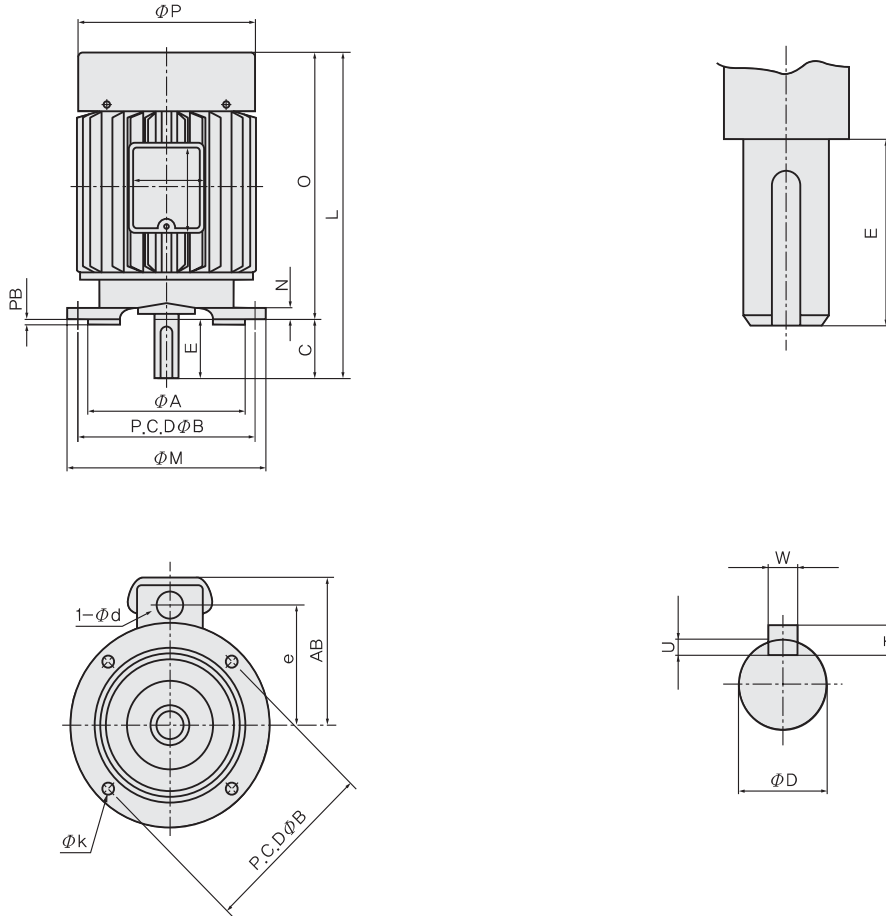

- 형 식 : VTFO-K
- 절연계급 : B
- Type : VTFO-K
- Insulation Class : B

프레임 Frame	출력(KW)		치 수 표 (Dimension)												축(Shaft)			
			전 동 기 (Motor)															
	4극	6극	L	ΦA	ΦB	C	E	AB	N	ΦM	O	ΦP	PB	ΦK	U	W	ΦD	T
63	0.2	-	230	110j6	130	23	23	-	8	-	207	132	3.5	10	1	-	11j6	-
71	0.4	-	225	110j6	130	30	30	134	10	160	225	132	3.5	10	3	5	14j6	5
80	0.4/0.75	0.4/0.75	293	130h7	165	40	40	140	12	200	253	175	4	12	3.5	6	19j6	6
90	1.5	0.75	356	130h7	165	50	50	161	12	200	306	192	4	12	4	8	24j6	7
100	2.2	1.5	368	180h7	215	60	60	168	16	250	308	196.5	4	15	4	8	28j6	7
112	2.2	1.5	389	180h7	215	60	60	182	16	250	327	235	4	15	4	8	28j6	7
112	3.7	2.2	412	180h7	215	60	60	182	16	250	352	235	4	15	4	8	28j6	7
132	5.5	3.7	458	230h7	265	80	80	213	20	300	378	274	4	15	5	10	38k6	8
132	7.5	5.5	498	230h7	265	80	80	213	20	300	418	274	4	15	5	10	38k6	8

▶ I.E.C FLANGE TYPE

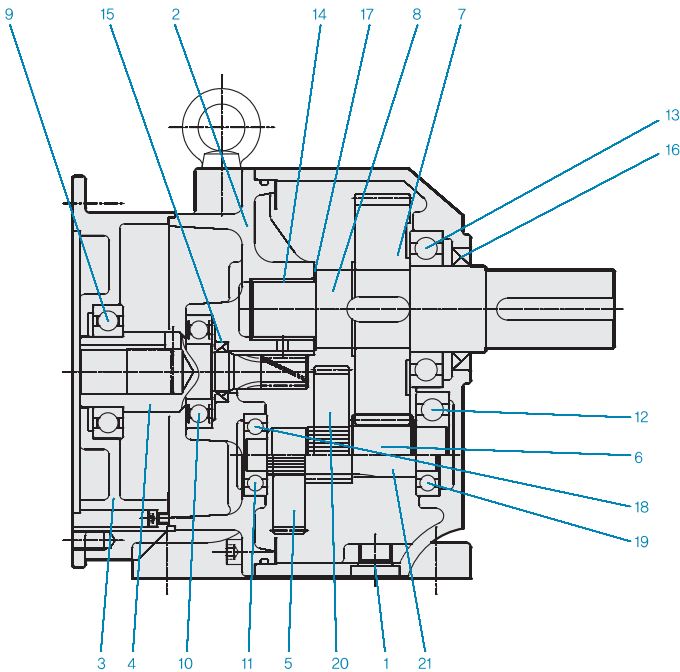
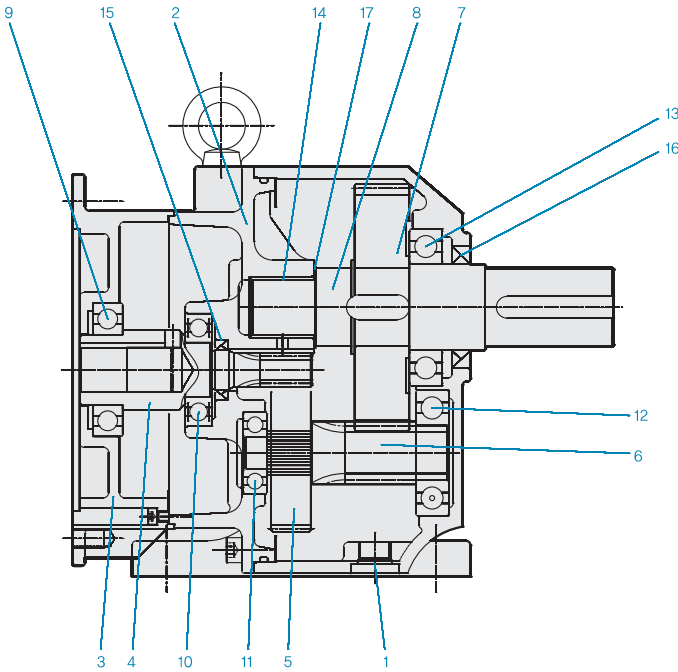

내부구조도
Inside Structure

- | | |
|--------|------------------|
| 케이스 | 1. Case |
| 모터 플랜지 | 2. Motor Flange |
| 모터 브라켓 | 3. Motor Bracket |
| 피니온 #1 | 4. 1st Pinion |
| 기어 #1 | 5. 1st Gear |
| 피니온 #2 | 6. 2nd Pinion |
| 기어 #2 | 7. 2nd Gear |
| 출력축 | 8. Output Shaft |
| 베어링 | 9. Bearing |
| 베어링 | 10. Bearing |
| 베어링 | 11. Bearing |
| 베어링 | 12. Bearing |
| 베어링 | 13. Bearing |
| 부쉬 | 14. Bush |
| 오일 씬 | 15. Oil Seal |
| 오일 씬 | 16. Oil Seal |
| 스페이서 | 17. Spacer |
| 베어링 | 18. Bearing |
| 베어링 | 19. Bearing |
| 기어 #3 | 20. 3rd Gear |
| 피니온 #3 | 21. 3rd Pinion |

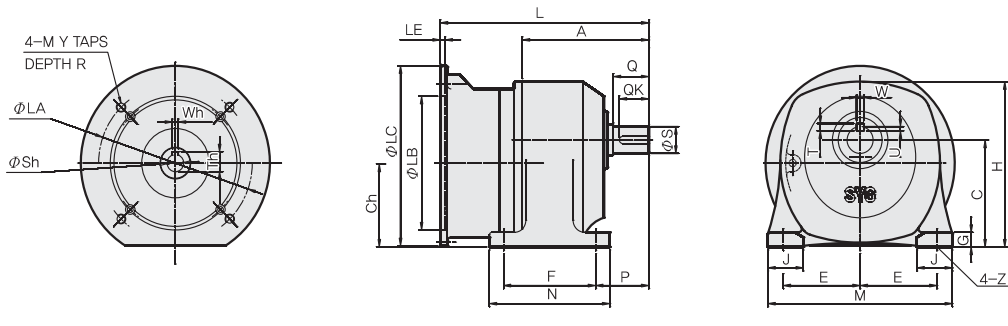

MOTOR (60Hz)KW		FRAME NO.	RATIO	MOTOR SIDE										C	E	F	G	H	I	J	L	M	N	P	Q	QK	S	T	U	W	Z
4P	6P			LA	LB	LC	LE	Sh	Wh	Th	A	Y	R																		
0.2	-	88	5 ~ 200	130	110	160	4	11	4	12.8	107	8	15	88	75	78	12	136	-	30	171.5	156	102	45	30	25	22	6	3.5	6	11
		105	90 ~ 200	130	110	160	4	11	4	12.8	127	8	15	105	67.5	90	14	162	-	35	191.5	175	120	60	40	35	28	7	4	7	12
0.4	-	88	5 ~ 30	130	110	160	4	14	5	16.3	107	8	15	88	75	78	12	136	-	30	176.5	156	102	45	30	25	22	6	3.5	6	11
		105	30 ~ 75	130	110	160	4	14	5	16.3	127	8	15	105	67.5	90	14	162	-	35	196.5	175	120	60	40	35	28	7	4	7	12
		135	90 ~ 200	130	110	160	4	14	5	16.3	162	8	15	135	90	135	18	204.5	237.8	45	231.5	210	165	72	55	50	32	10	5	8	15
0.75	0.4	105	5 ~ 30	165	130	200	4	19	6	21.2	127	10	-	105	67.5	90	14	162	-	35	213	175	120	60	40	35	28	7	4	7	12
		135	40 ~ 75	165	130	200	4	19	6	21.8	162	10	-	135	90	135	18	204.5	237.8	45	265	210	165	72	55	50	32	8	5	10	15
		153	90 ~ 200	165	130	200	4	19	6	21.8	185.5	10	-	153	107.5	150	20	231	264.3	55	259	250	185	83	60	55	40	8	5	12	15
1.5	0.75	135	5 ~ 30	165	130	200	4	24	8	27.3	162	10	-	135	90	135	18	204.5	237.8	45	267	210	165	72	55	50	32	8	5	10	15
		153	40 ~ 75	165	130	200	4	24	8	27.3	185.5	10	-	153	107.5	150	20	231	264.3	55	280.5	250	185	83	60	55	40	8	5	12	15
		172	90 ~ 200	165	130	200	4	24	8	27.3	229.5	10	-	172	116	172	23	262	303.5	65	325.5	288	216	113.5	82	75	50	9	5.5	14	19
2.2	1.5	153	5 ~ 30	215	180	250	4.5	28	8	31.3	185.5	10	-	153	107.5	150	20	231	264.3	55	297.5	250	185	83	60	55	40	8	5	12	15
		172	40 ~ 75	215	180	250	4.5	28	8	31.3	229.5	12	20	172	116	172	23	262	303.5	65	345.5	288	216	113.5	82	75	50	9	5.5	14	19
3.7	2.2	172	5 ~ 30	215	180	250	4.5	28	8	31.3	229.5	12	20	172	116	172	23	262	303.5	65	345.5	288	216	113.5	82	75	50	9	5.5	14	19

0.2KW 1/4HP 3-phase 삼상

MAXII 외형도 Specifications

동력(Kw) POWER	형번	비율 RATIO	R.P.M	TORQUE (Kgf.m)	O.H.L (Kgf)	WEIGHT(KG)		형번	비율 RATIO	R.P.M	TORQUE (Kgf.m)	O.H.L (Kgf)	WEIGHT(KG)	
						HT	VT						HT	VT
0.2 (삼상)	88	1 / 5	350	0.5	60	7.8	8.2	88 (정토크)	1 / 150	11.7	7.6	340	8	8.5
		1 / 10	175	1.0	90	7.8	8.2		1 / 160	10.9	7.6	350	8	8.5
		1 / 15	116.7	1.6	100	7.8	8.2		1 / 180	9.7	7.6	350	8	8.5
		1 / 20	87.5	2.1	120	7.8	8.2		1 / 200	8.8	7.6	350	8	8.5
		1 / 30	58.3	3.1	180	7.8	8.2		1 / 90	19.4	9.2	250	9	9.5
		1 / 40	43.8	4.1	190	7.8	8.2		1 / 100	17.5	10.2	290	9	9.5
		1 / 50	35	5.1	200	7.8	8.2		1 / 120	14.6	11.7	340	9	9.5
		1 / 60	29.2	6.2	220	7.8	8.2		1 / 140	12.5	13.6	340	9	9.5
	88 (정토크)	1 / 75	23.3	7.6	250	7.8	8.2	105	1 / 150	11.7	14.6	340	9	9.5
		1 / 90	19.4	7.6	250	7.8	8.2		1 / 160	10.9	15.6	350	9	9.5
		1 / 100	17.5	7.6	290	8	8.2		1 / 180	9.7	18.0	350	9	9.5
		1 / 120	14.6	7.6	340	8	8.5		1 / 200	8.8	19.5	350	9	9.5
		1 / 140	12.5	7.6	340	8	8.5							

MAXII 88 HORIZONTAL 3-phase

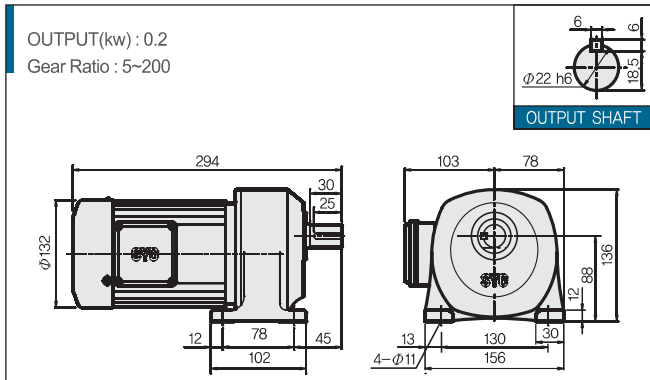

MAXII 88 VERTICAL 3-phase

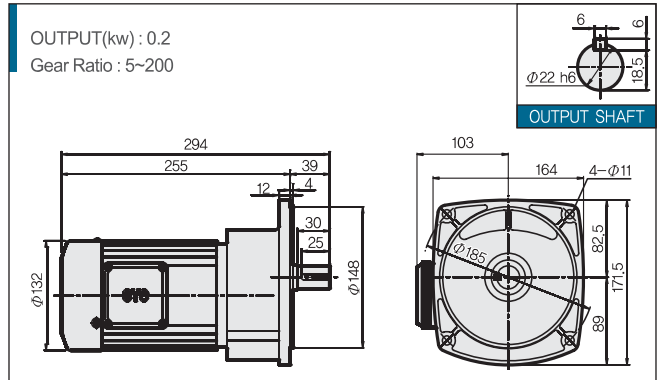

MAXII 105 HORIZONTAL 3-phase

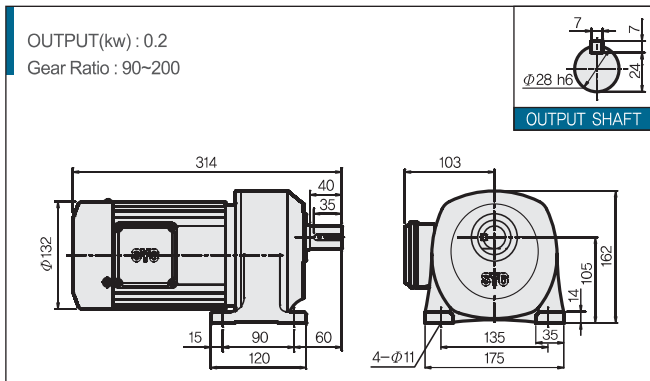

MAXII 105 VERTICAL 3-phase

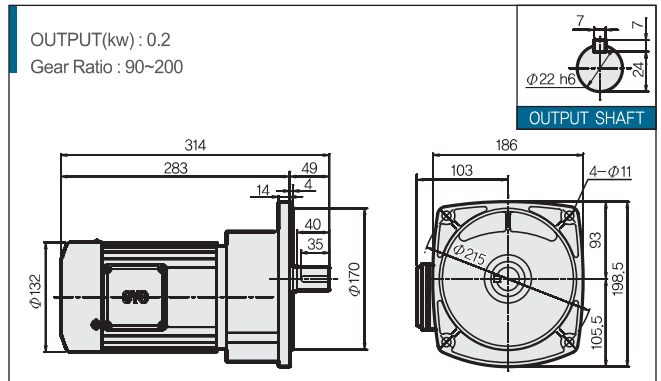

GEARED MOTORS

0.2KW 1/4HP 1-phase 단상

MAXII 외형도 Specifications

동력(kw) POWER	형번	비율 RATIO	R.P.M	TORQUE (Kgf.m)	O.H.L (Kgf)	WEIGHT(KG)		형번	비율 RATIO	R.P.M	TORQUE (Kgf.m)	O.H.L (Kgf)	WEIGHT(KG)	
						HT	VT						HT	VT
0.2 (단상)	88	1 / 5	350	0.5	60	9.8	10	88 (정토크)	1 / 150	11.7	7.6	340	9.8	10
		1 / 10	175	1.0	90	9.8	10		1 / 160	10.9	7.6	350	9.8	10
		1 / 15	116.7	1.6	100	9.8	10		1 / 180	9.7	7.6	350	9.8	10
		1 / 20	87.5	2.1	120	9.8	10		1 / 200	8.8	7.6	350	9.8	10
		1 / 30	58.3	3.1	180	9.8	10		1 / 90	19.4	9.2	250	10	11
		1 / 40	43.8	4.1	190	9.8	10		1 / 100	17.5	10.2	290	10	11
		1 / 50	35	5.1	200	9.8	10		1 / 120	14.6	11.7	340	10	11
		1 / 60	29.2	6.2	220	9.8	10		1 / 140	12.5	13.6	340	10	11
	88 (정토크)	1 / 75	23.3	7.6	250	9.8	10	105	1 / 150	11.7	14.6	340	10	11
		1 / 90	19.4	7.6	250	9.8	10		1 / 160	10.9	15.6	350	10	11
		1 / 100	17.5	7.6	290	9.8	10		1 / 180	9.7	18.0	350	10	11
		1 / 120	14.6	7.6	340	9.8	10		1 / 200	8.8	19.5	350	10	11
		1 / 140	12.5	7.6	340	9.8	10							

MAXII 88 HORIZONTAL 1-phase

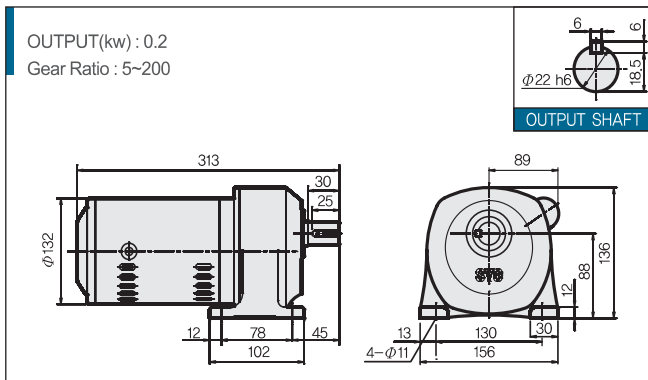

MAXII 88 VERTICAL 1-phase

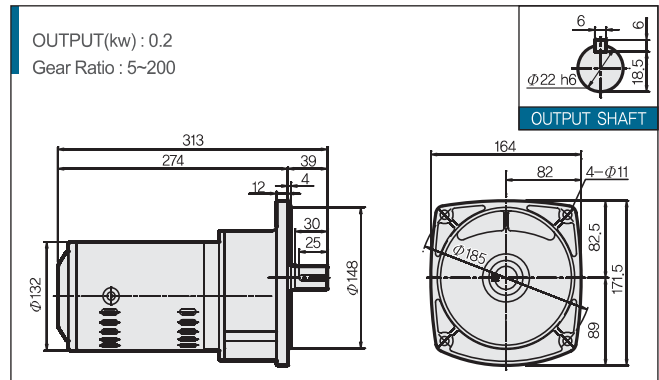

MAXII 105 HORIZONTAL 1-phase

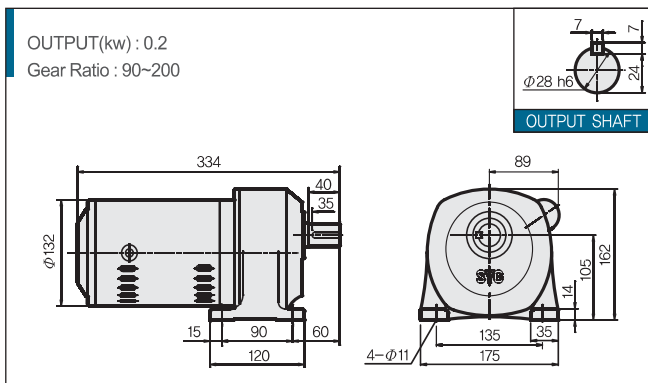

MAXII 105 VERTICAL 1-phase

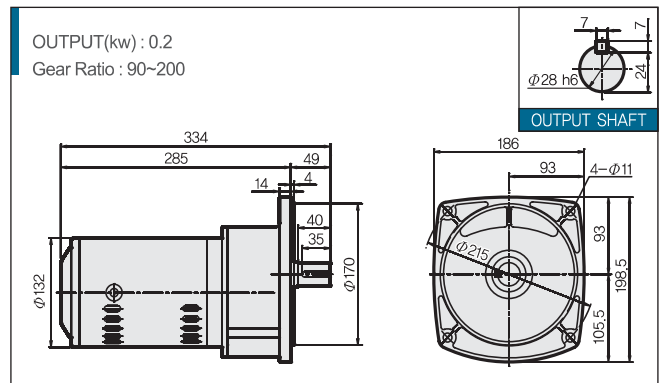

0.2KW LINE POWER

MAXII 88 LINE POWER I

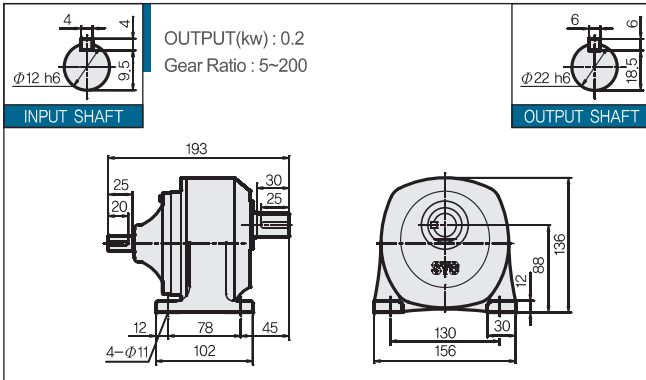

MAXII 105 LINE POWER I

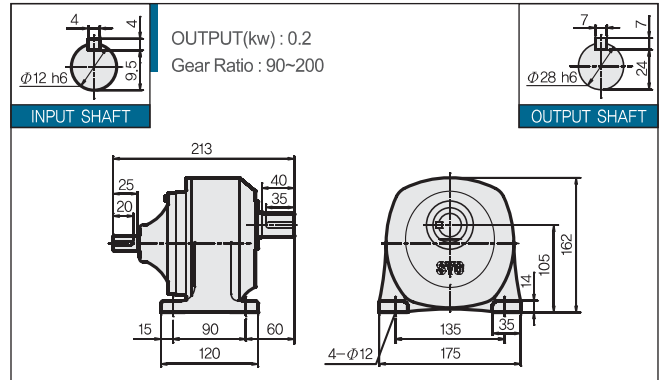

GEARED MOTORS

0.4KW 2/4HP 3-phase 삼상

MAXII 외형도 Specifications

동력(kw) POWER	형번	비율 RATIO	R.P.M	TORQUE (Kgf.m)	O.H.L (Kgf)	WEIGHT(KG)		형번	비율 RATIO	R.P.M	TORQUE (Kgf.m)	O.H.L (Kgf)	WEIGHT(KG)	
						HT	VT						HT	VT
0.4 (삼상)	88	1 / 5	350	1	90	10	10.3	135	1 / 90	19.4	18	350	22	23.1
		1 / 10	175	2.1	120	10	10.3		1 / 100	17.5	20.3	500	22	23.1
		1 / 15	116.7	3.1	140	10	10.3		1 / 120	14.6	23.4	600	22	23.1
		1 / 20	87.5	4.2	150	10	10.3		1 / 140	12.5	27.3	600	22	23.1
		1 / 30	58.3	6.1	260	10	10.3		1 / 150	11.7	29.2	600	22	23.1
		1 / 40	43.8	8.1	290	11.5	12		1 / 160	10.9	31.2	600	22	23.1
	105	1 / 50	35	10.2	320	11.5	12	1 / 180	9.7	32	600	22	23.1	
		1 / 60	29.2	12.2	350	11.5	12	1 / 200	8.8	32	600	22	23.1	
		1 / 75	23.3	15.3	350	11.5	12							

MAXII 88 HORIZONTAL 3-phase

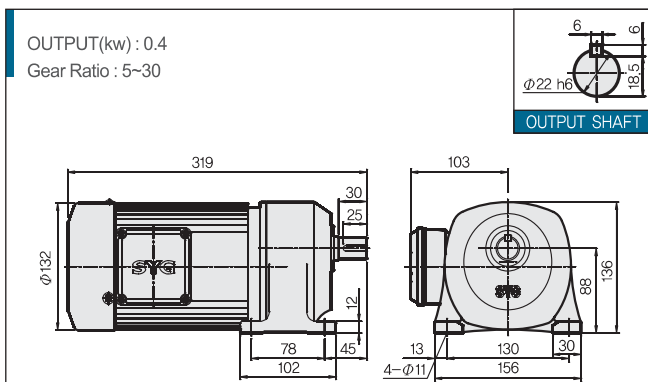

MAXII 88 VERTICAL 3-phase

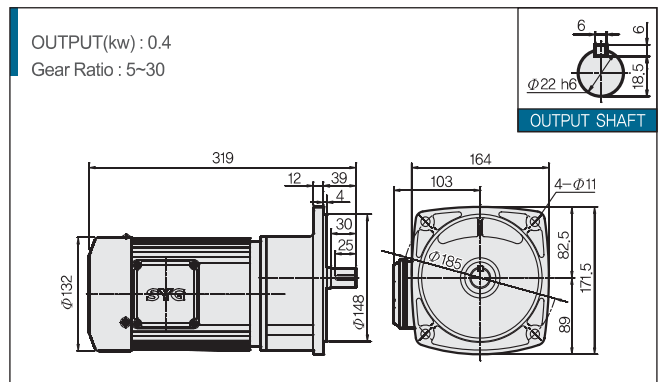

MAXII 105 HORIZONTAL 3-phase

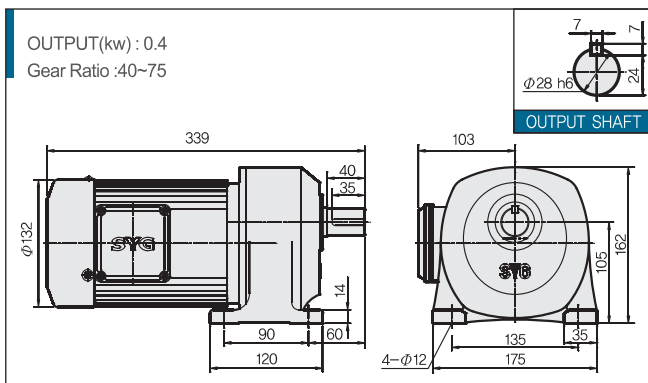

MAXII 105 VERTICAL 3-phase

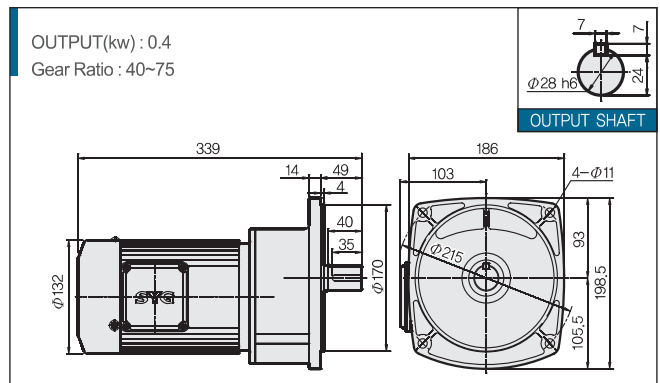

MAXII 135 HORIZONTAL 3-phase

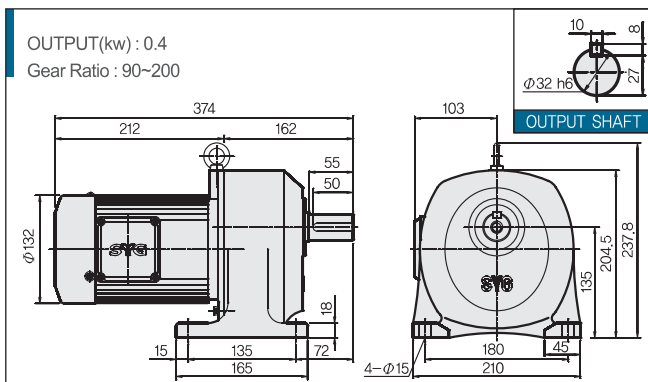

MAXII 135 VERTICAL 3-phase

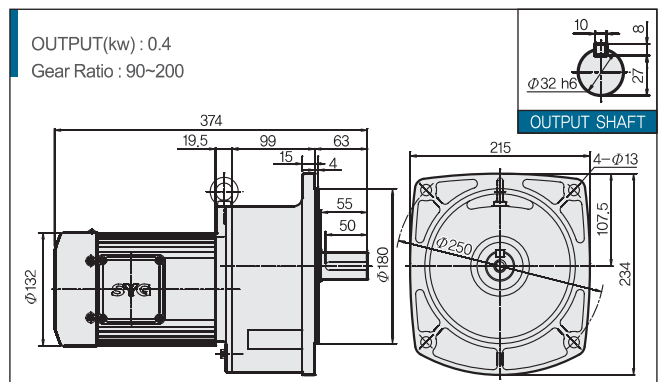

0.4KW 2/4HP 1-phase 단상

MAXII 외형도 Specifications

동력(Kw) POWER	형번	비율 RATIO	R.P.M	TORQUE (Kgf.m)	O.H.L (Kgf)	WEIGHT(KG)		형번	비율 RATIO	R.P.M	TORQUE (Kgf.m)	O.H.L (Kgf)	WEIGHT(KG)		
						HT	VT						HT	VT	
0.4 (단상)	88	1 / 5	350	1	90	14.5	14.7	135	1 / 90	19.4	18	350	27.2	28.3	
		1 / 10	175	2.1	120	14.5	14.7		1 / 100	17.5	20.3	500	27.2	28.3	
		1 / 15	116.7	3.1	140	14.5	14.7		1 / 120	14.6	23.4	600	27.2	28.3	
		1 / 20	87.5	4.2	150	14.5	14.7		1 / 140	12.5	27.3	600	27.2	28.3	
		1 / 30	58.3	6.1	260	14.5	14.7		1 / 150	11.7	29.2	600	27.2	28.3	
		1 / 40	43.8	8.1	290	16.1	16.5		1 / 160	10.9	31.2	600	27.2	28.3	
	105	1 / 50	35	10.2	320	16.1	16.5		1 / 180	9.7	32	600	27.2	28.3	
		1 / 60	29.2	12.2	350	16.1	16.5		1 / 200	8.8	32	600	27.2	28.3	
		1 / 75	23.3	15.3	350	16.1	16.5								

MAXII 88 HORIZONTAL 1-phase

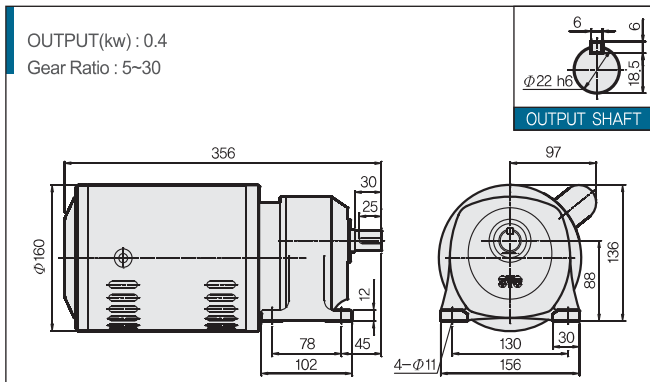

MAXII 88 VERTICAL 1-phase

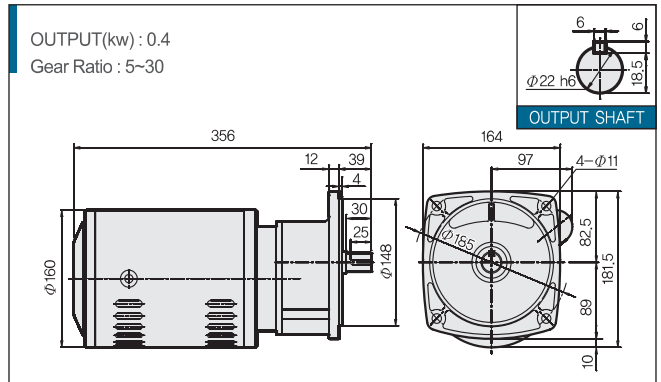

MAXII 105 HORIZONTAL 1-phase

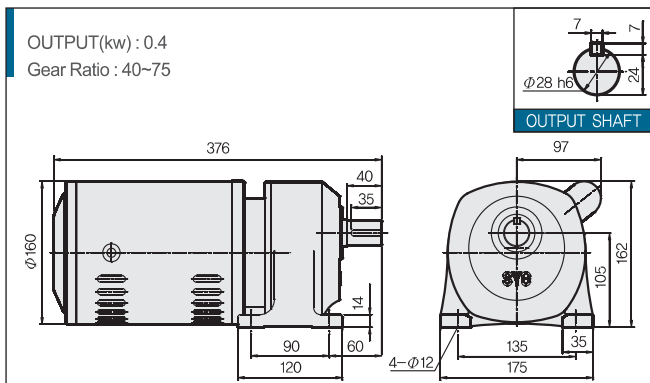

MAXII 105 VERTICAL 1-phase

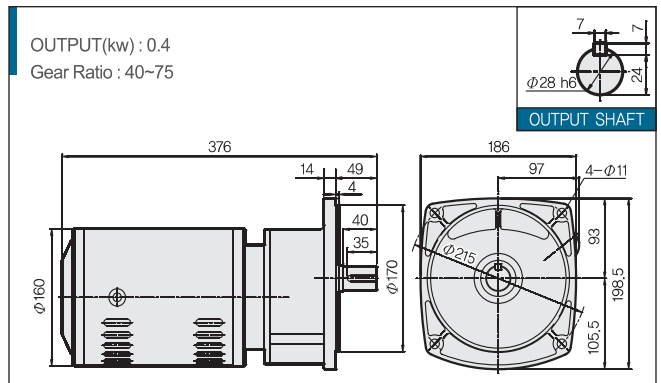

MAXII 135 HORIZONTAL 1-phase

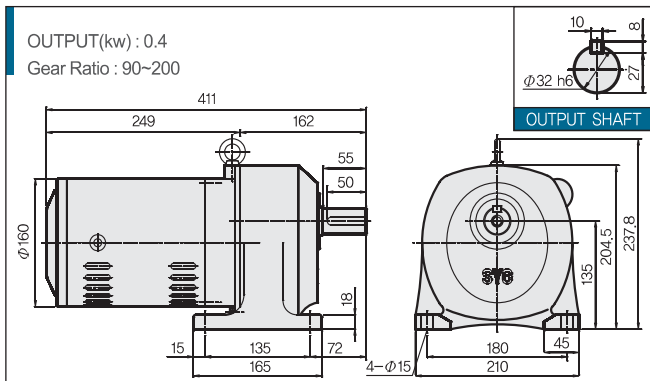

MAXII 135 VERTICAL 1-phase

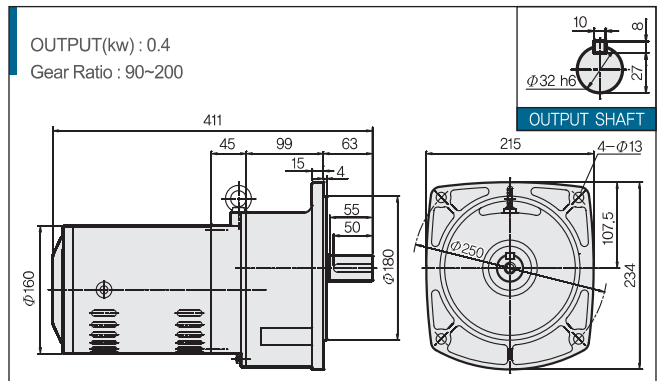

0.4KW LINE POWER

MAXII 88 LINE POWER I

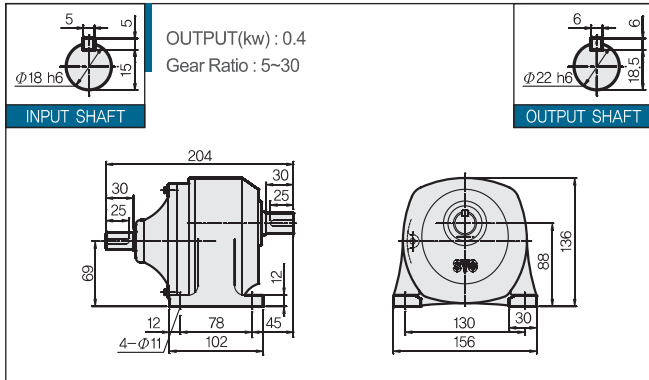

MAXII 105 LINE POWER I

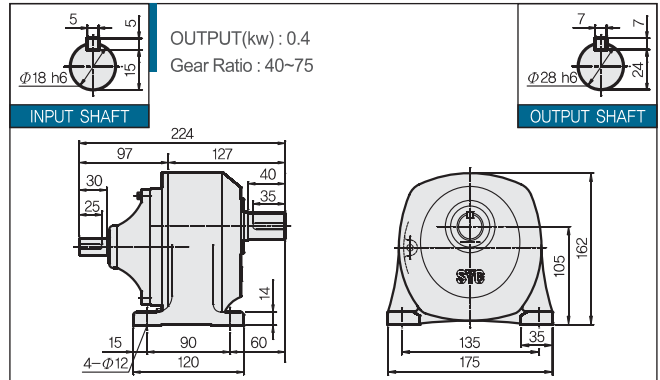

MAXII 135 LINE POWER I

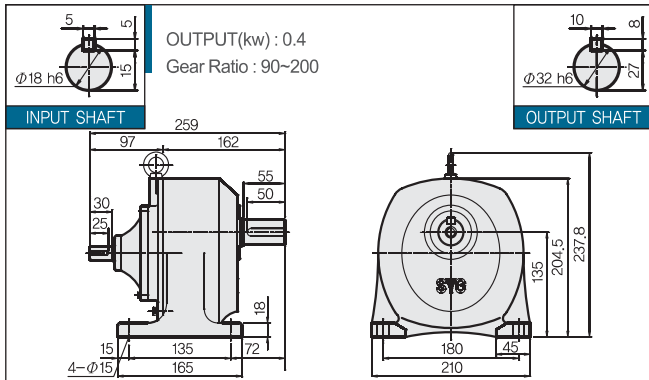

0.75KW 1HP 3-phase 삼상

MAXII 외형도 Specifications

동력(Kw) POWER	형번	비율 RATIO	R.P.M	TORQUE (Kgf.m)	O.H.L (Kgf)	WEIGHT(KG)		형번	비율 RATIO	R.P.M	TORQUE (Kgf.m)	O.H.L (Kgf)	WEIGHT(KG)		
						HT	VT						HT	VT	
0.75 (삼상)	105	1 / 5	350	2	130	17	17.5	153	1 / 90	19.4	34.3	650	32	34.7	
		1 / 10	175	4	180	17	17.5		1 / 100	17.5	38.1	720	32	34.7	
		1 / 15	116.7	5.8	220	17	17.5		1 / 120	14.6	43.8	720	32	34.7	
		1 / 20	87.5	7.8	240	17	17.5		1 / 140	12.5	51	720	32	34.7	
		1 / 30	58.3	11.4	410	17	17.5		1 / 150	11.7	54.8	720	32	34.7	
		1 / 40	43.8	15.3	430	24.5	25.7		1 / 160	10.9	58.4	720	32	34.7	
	135	1 / 50	35	19.1	470	24.5	25.7		1 / 180	9.7	60	720	32	34.7	
		1 / 60	29.2	22.9	560	24.5	25.7		1 / 200	8.8	60	720	32	34.7	
		1 / 75	23.3	28.6	600	24.5	25.7								

MAXII 105 HORIZONTAL 3-phase

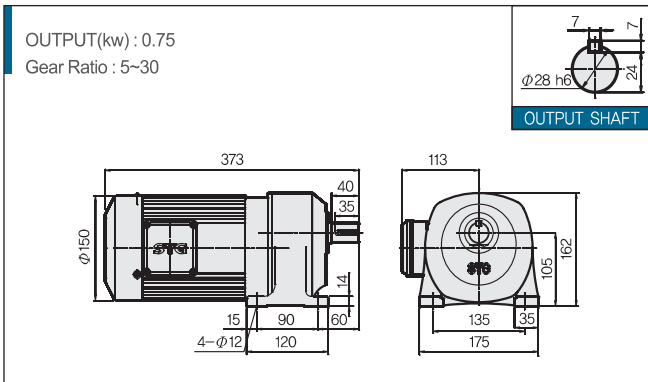

MAXII 105 VERTICAL 3-phase

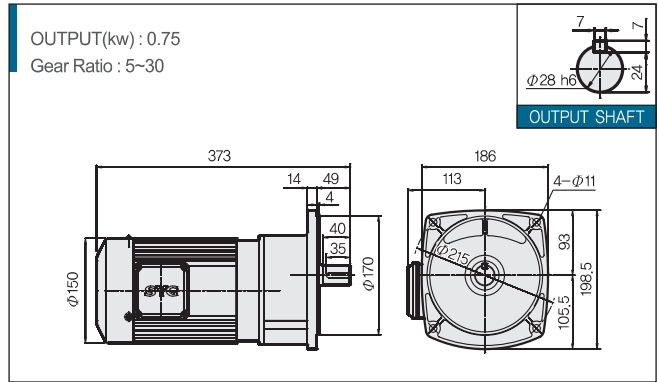

MAXII 135 HORIZONTAL 3-phase

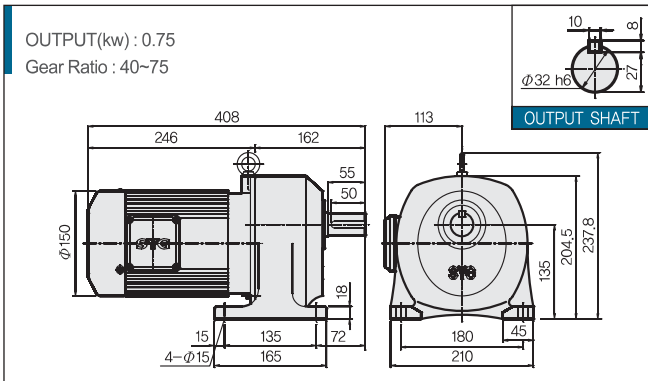

MAXII 135 VERTICAL 3-phase

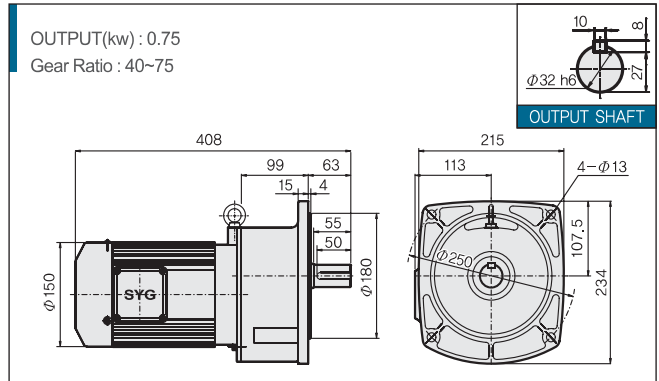

MAXII 153 HORIZONTAL 3-phase

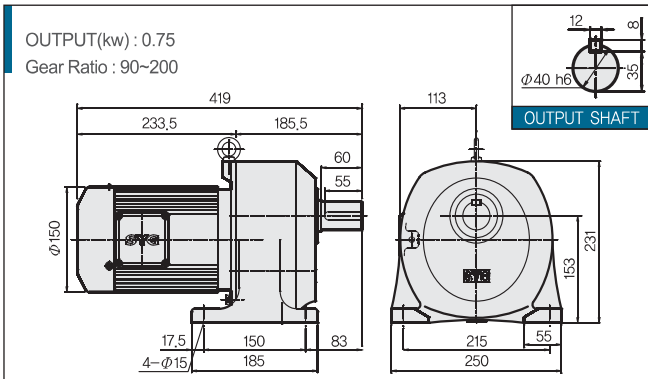

MAXII 153 VERTICAL 3-phase

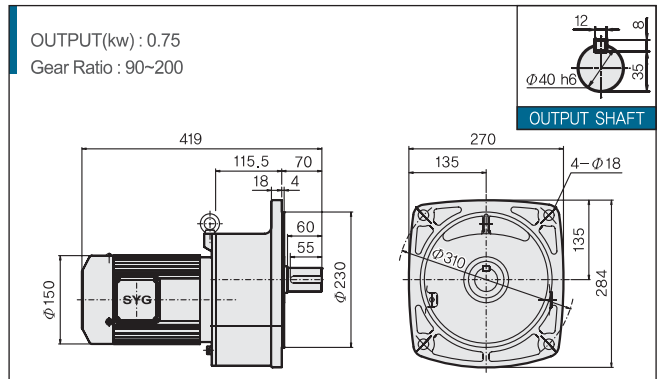

0.75KW 1HP 1-phase 단상

MAXII 외형도 Specifications

동력(Kw) POWER	형번	비율 RATIO	R.P.M	TORQUE (Kgf.m)	O.H.L (Kgf)	WEIGHT(KG)		형번	비율 RATIO	R.P.M	TORQUE (Kgf.m)	O.H.L (Kgf)	WEIGHT(KG)		
						HT	VT						HT	VT	
0.75 (단상)	105	1 / 5	350	2	130	21,6	22	153	1 / 90	19,4	34,3	650	31	41	
		1 / 10	175	4	180	21,6	22		1 / 100	17,5	38,1	720	31	41	
		1 / 15	116,7	5,8	220	21,6	22		1 / 120	14,6	43,8	720	31	41	
		1 / 20	87,5	7,8	240	21,6	22		1 / 140	12,5	51	720	31	41	
		1 / 30	58,3	11,4	410	21,6	22		1 / 150	11,7	54,8	720	31	41	
		1 / 40	43,8	15,3	430	30	31		1 / 160	10,9	58,4	720	31	41	
	135	1 / 50	35	19,1	470	30	31		1 / 180	9,7	60	720	31	41	
		1 / 60	29,2	22,9	560	30	31		1 / 200	8,8	60	720	31	41	
		1 / 75	23,3	28,6	600	30	31								

MAXII 105 HORIZONTAL 1-phase

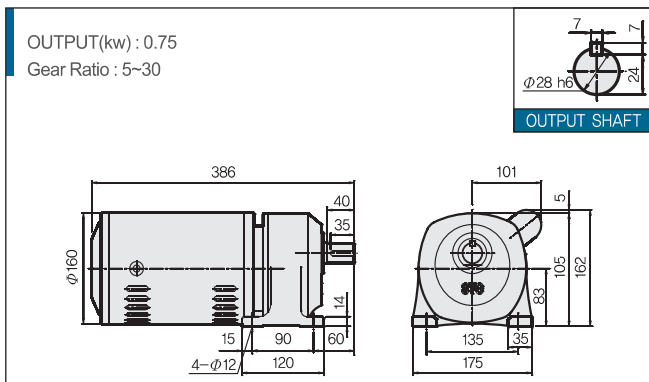

MAXII 105 VERTICAL 1-phase

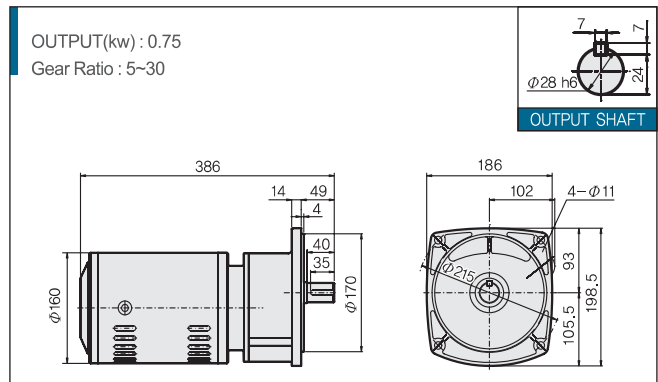

MAXII 135 HORIZONTAL 1-phase

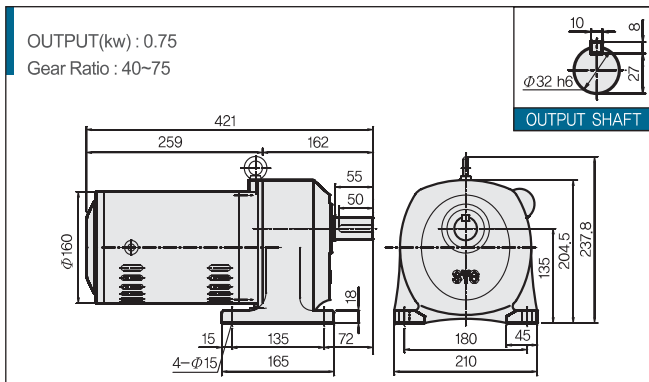

MAXII 135 VERTICAL 1-phase

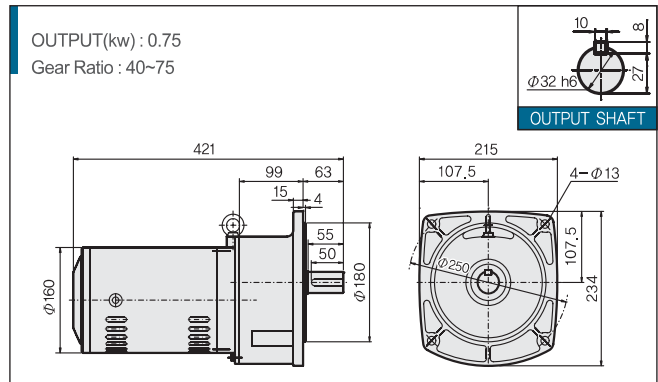

MAXII 153 HORIZONTAL 1-phase

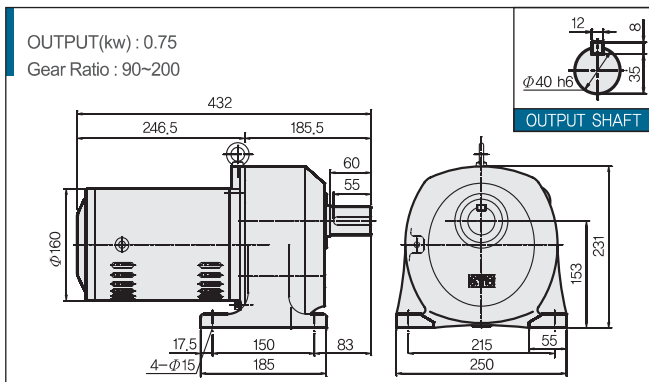

MAXII 153 VERTICAL 1-phase

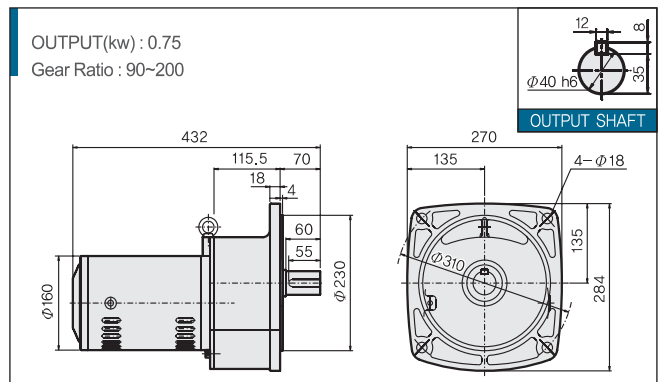

0.75KW LINE POWER

MAXII 105 LINE POWER I

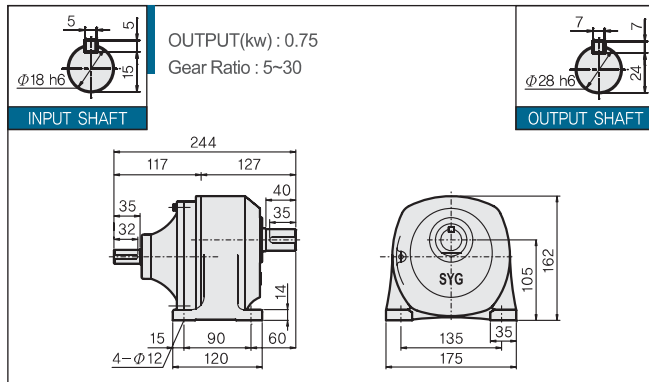

MAXII 135 LINE POWER I

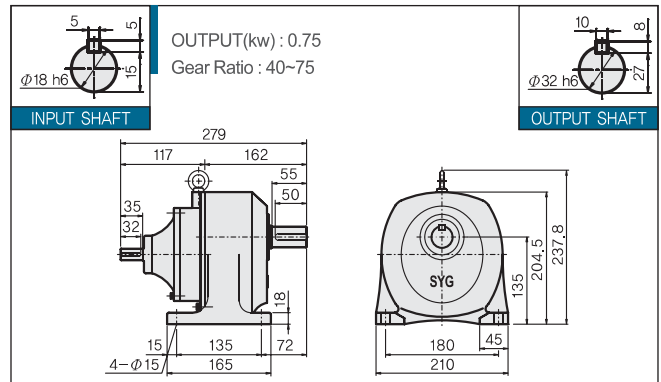

MAXII 153 LINE POWER I

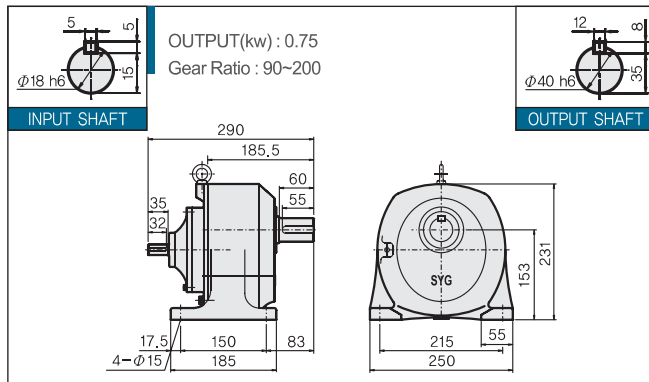

GEARED MOTORS

1.5KW 2HP 3-phase 삼상

MAXII 외형도 Specifications

동력(kw) POWER	형번	비율 RATIO	R.P.M	TORQUE (Kgf.m)	O.H.L (Kgf)	WEIGHT(KG)		형번	비율 RATIO	R.P.M	TORQUE (Kgf.m)	O.H.L (Kgf)	WEIGHT(KG)		
						HT	VT						HT	VT	
1.5 (삼상)	135	1 / 5	350	4	180	29	30	172	1 / 90	19.4	68.7	720	50	53.1	
		1 / 10	175	7.8	250	29	30		1 / 100	17.5	76.3	1000	50	53.1	
		1 / 15	116.7	11.7	290	29	30		1 / 120	14.6	87.7	1000	50	53.1	
		1 / 20	87.5	15.6	330	29	30		1 / 140	12.5	102	1000	50	53.1	
		1 / 30	58.3	22.9	520	29	30		1 / 150	11.7	110	1000	50	53.1	
		1 / 40	43.8	30.5	600	37.6	40		1 / 160	10.9	116.9	1000	50	53.1	
	153	1 / 50	35	36.5	720	37.6	40		1 / 180	9.7	131.5	1000	50	53.1	
		1 / 60	29.2	45.8	720	37.6	40		1 / 200	8.8	137	1000	50	53.1	
		1 / 75	23.3	57.8	720	37.6	40								

MAXII 135 HORIZONTAL 3-phase

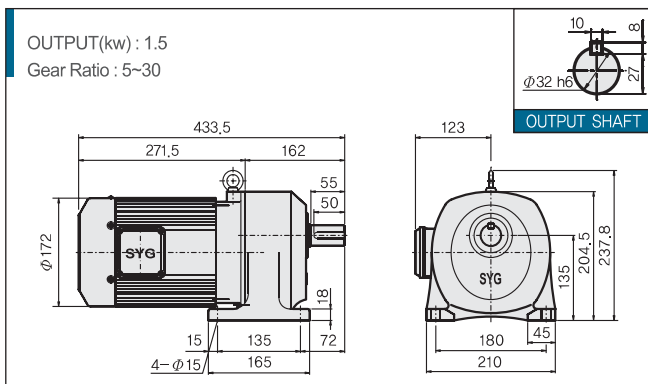

MAXII 135 VERTICAL 3-phase

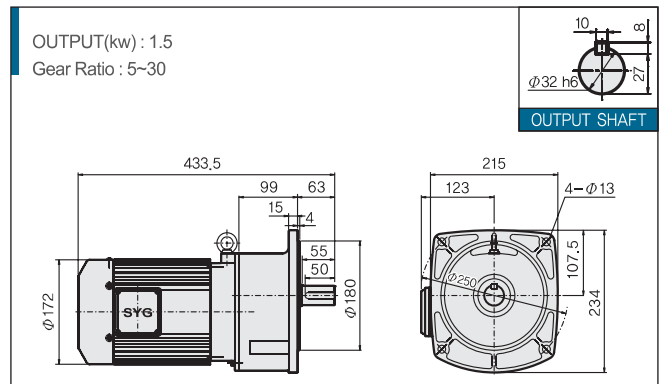

MAXII 153 HORIZONTAL 3-phase

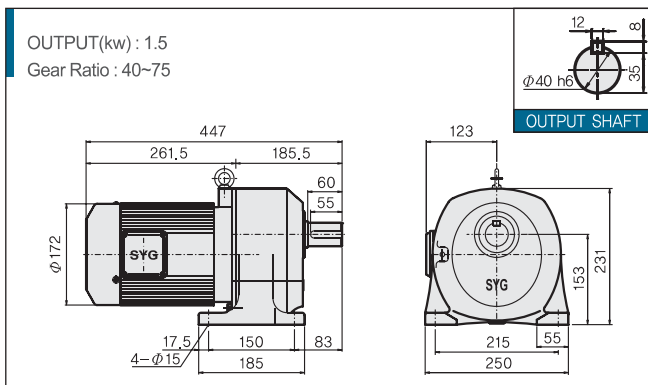

MAXII 153 VERTICAL 3-phase

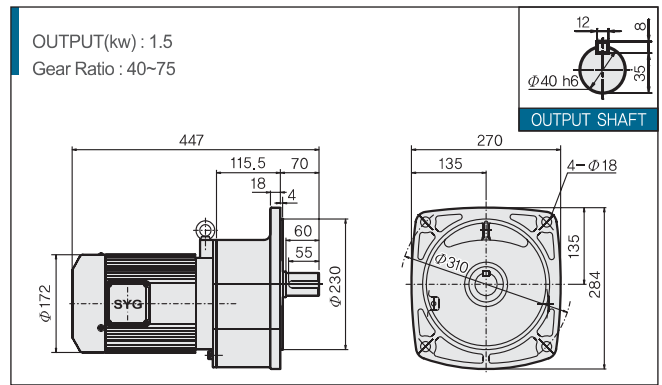

MAXII 172 HORIZONTAL 3-phase

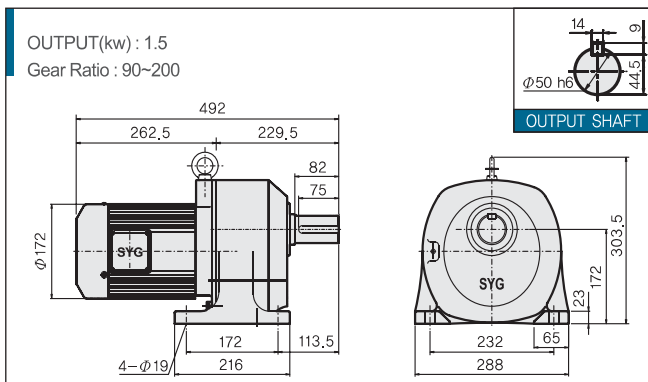

MAXII 172 VERTICAL 3-phase

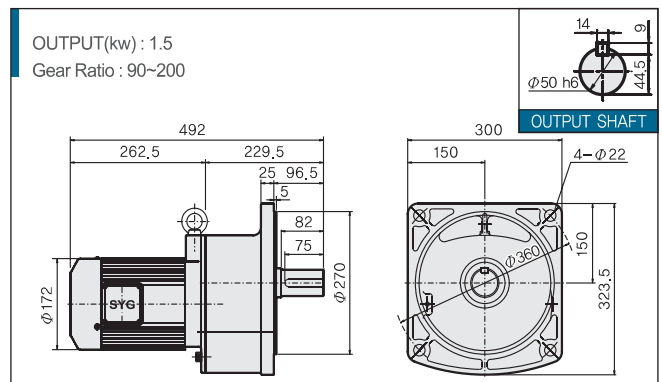

1.5KW 2HP 1-phase 단상

MAXII 외형도 Specifications

동력(Kw) POWER	형번	비율 RATIO	R.P.M	TORQUE (Kgf.m)	O.H.L (Kgf)	WEIGHT(KG)		형번	비율 RATIO	R.P.M	TORQUE (Kgf.m)	O.H.L (Kgf)	WEIGHT(KG)		
						HT	VT						HT	VT	
1.5 (단상)	135	1 / 5	350	4	180	5,2	36,5	172	1 / 90	19,4	68,7	720	56,7	61	
		1 / 10	175	7,8	250	35,2	36,5		1 / 100	17,5	76,3	1000	56,7	61	
		1 / 15	116,7	11,7	290	35,2	36,5		1 / 120	14,6	87,7	1000	56,7	61	
		1 / 20	87,5	15,6	330	35,2	36,5		1 / 140	12,5	102	1000	56,7	61	
		1 / 30	58,3	22,9	520	35,2	36,5		1 / 150	11,7	110	1000	56,7	61	
		1 / 40	43,8	30,5	600	43	45,6		1 / 160	10,9	116,9	1000	56,7	61	
	153	1 / 50	35	36,5	720	43	45,6		1 / 180	9,7	131,5	1000	56,7	61	
		1 / 60	29,2	45,8	720	43	45,6		1 / 200	8,8	137	1000	56,7	61	
		1 / 75	23,3	57,8	720	43	45,6								

MAXII 135 HORIZONTAL 1-phase

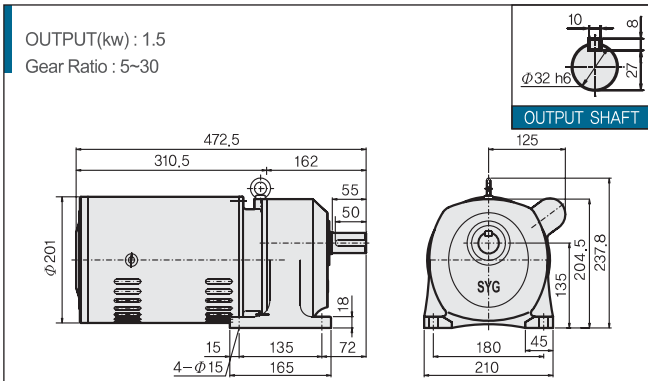

MAXII 135 VERTICAL 1-phase

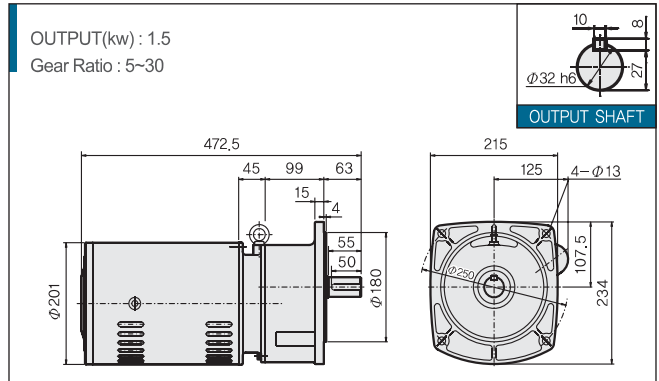

MAXII 153 HORIZONTAL 1-phase

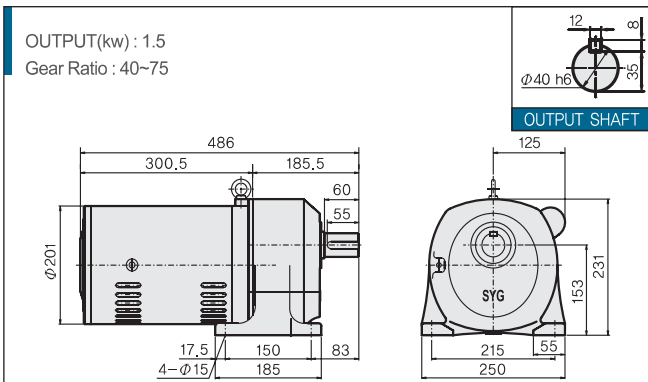

MAXII 153 VERTICAL 1-phase

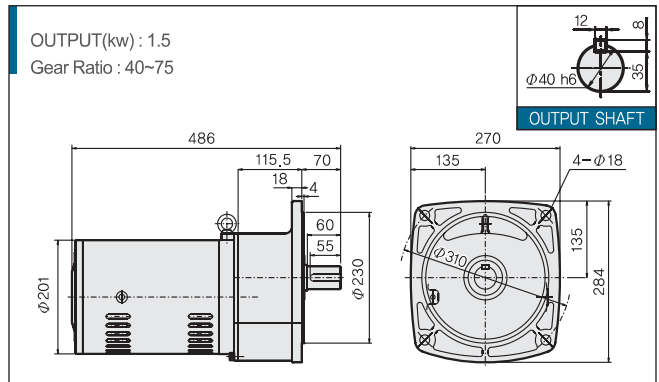

MAXII 172 HORIZONTAL 1-phase

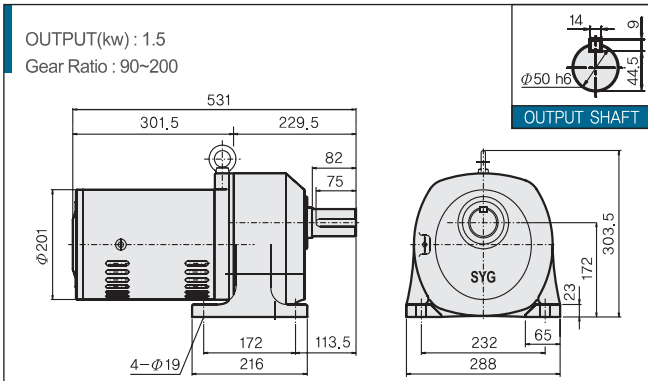

MAXII 172 VERTICAL 1-phase

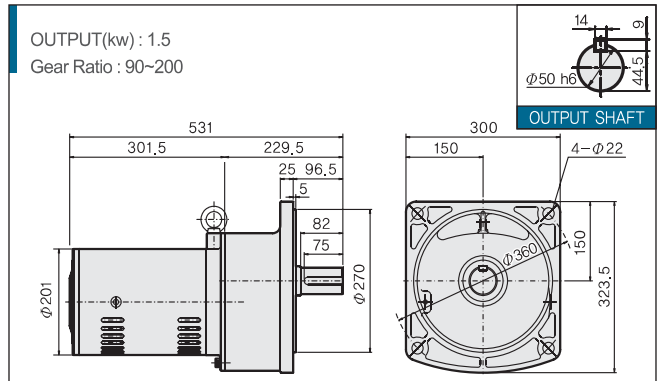

1.5KW LINE POWER

MAXII 135 LINE POWER I

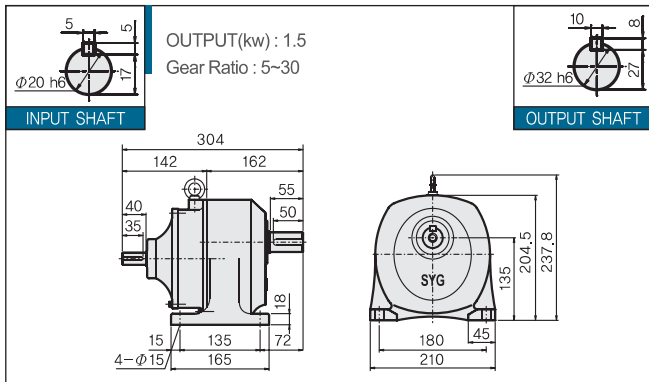

MAXII 153 LINE POWER I

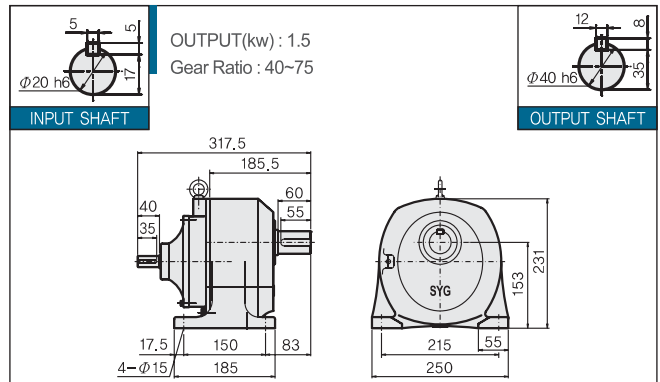

MAXII 172 LINE POWER I

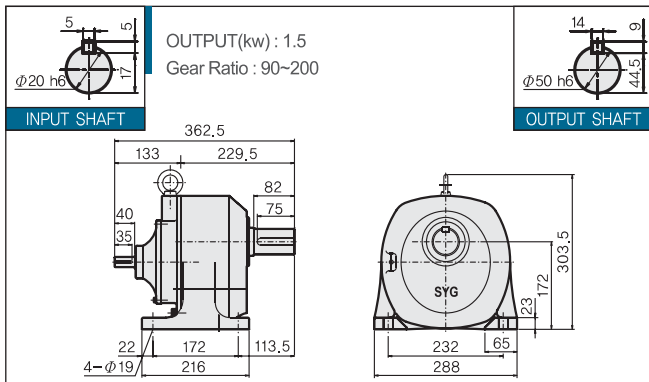

2.2KW 3HP 3-phase 삼상

MAXII 외형도 Specifications

동력(Kw) POWER	형번	비율 RATIO	R.P.M	TORQUE (Kgf.m)	O.H.L (Kgf)	WEIGHT(KG)		형번	비율 RATIO	R.P.M	TORQUE (Kgf.m)	O.H.L (Kgf)	WEIGHT(KG)		
						HT	VT						HT	VT	
2.2 (삼상)	153	1 / 5	350	5.7	220	50.3	53	172	1 / 40	43.8	44.8	740	61.8	65	
		1 / 10	175	11.4	320	50.3	53		1 / 50	35	56	880	61.8	65	
		1 / 15	116.7	17	360	50.3	53		1 / 60	29.2	67.1	1000	61.8	65	
		1 / 20	87.5	22.9	410	50.3	53		1 / 75	23.3	83.9	1000	61.8	65	
		1 / 30	58.3	33.6	710	50.3	53								

MAXII 153 HORIZONTAL 3-phase

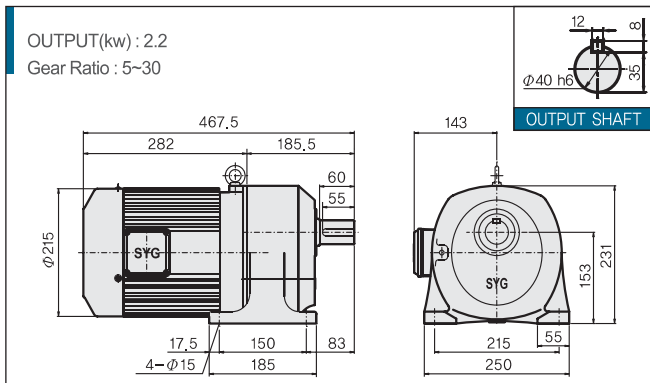

MAXII 153 VERTICAL 3-phase

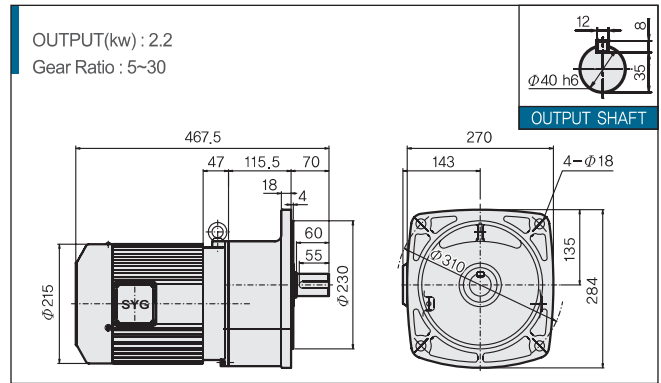

MAXII 172 HORIZONTAL 3-phase

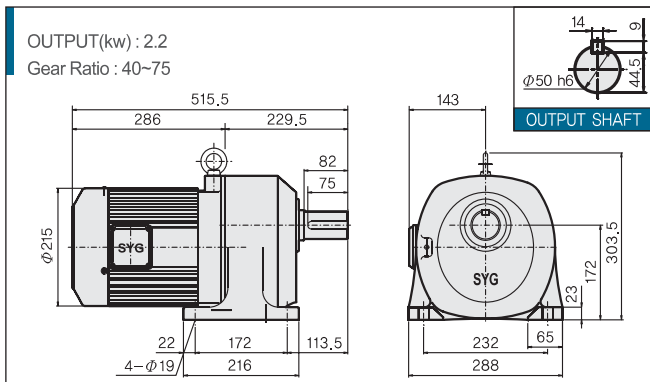

MAXII 172 VERTICAL 3-phase

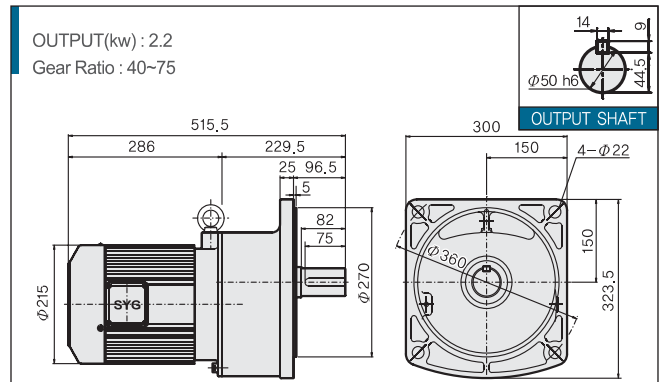

2.2KW LINE POWER

MAXII 153 LINE POWER

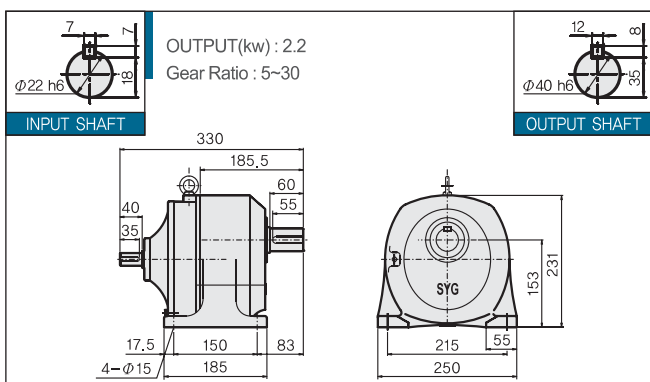

MAXII 172 LINE POWER

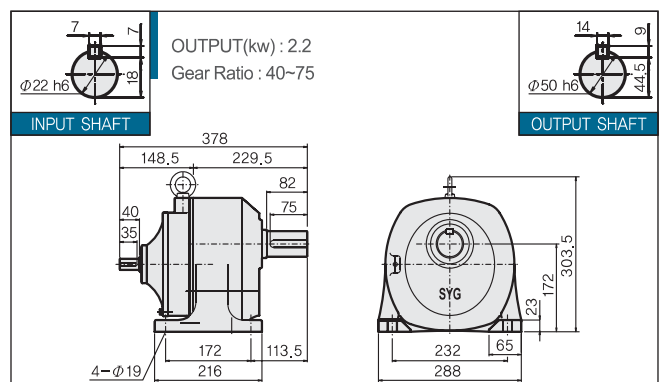

3.7KW 5HP 3-phase 삼상

MAXII 외형도 Specifications

동력(Kw) POWER	형번	비율 RATIO	R.P.M	TORQUE (Kgf.m)	O.H.L (Kgf)	WEIGHT(KG)	
						HT	VT
3.7 (삼상)	172	1 / 5	350	9,6	320	65,5	69
		1 / 10	175	19	400	65,5	69
		1 / 15	116.7	28,8	450	65,5	69
		1 / 20	87,5	38	710	65,5	69
		1 / 30	58,3	56,5	880	65,5	69

MAXII 172 HORIZONTAL 3-phase

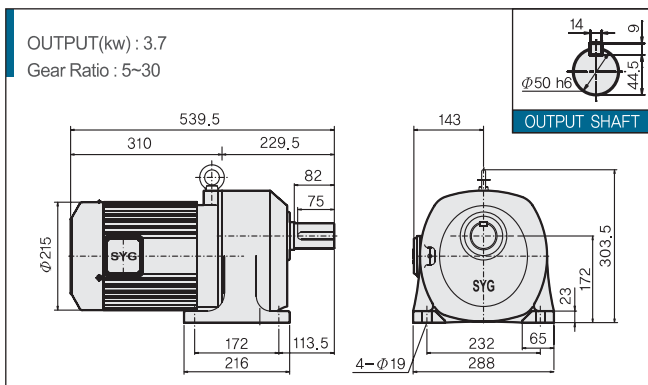

MAXII 172 VERTICAL 3-phase

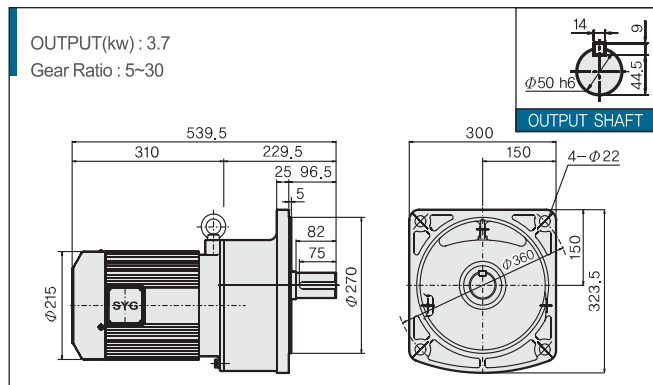

3.7KW LINE POWER

MAXII 172 LINE POWER

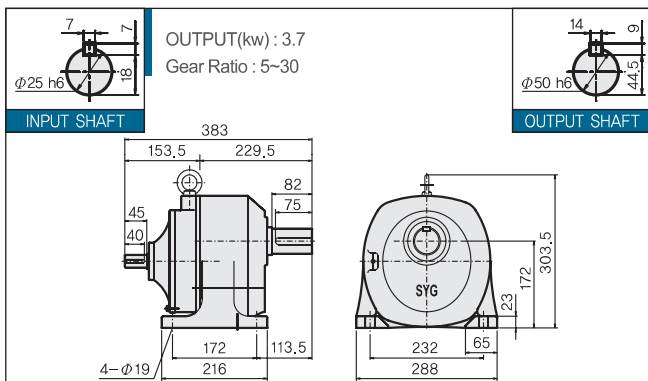

SAMYANG MAXII GEARED MOTOR

