

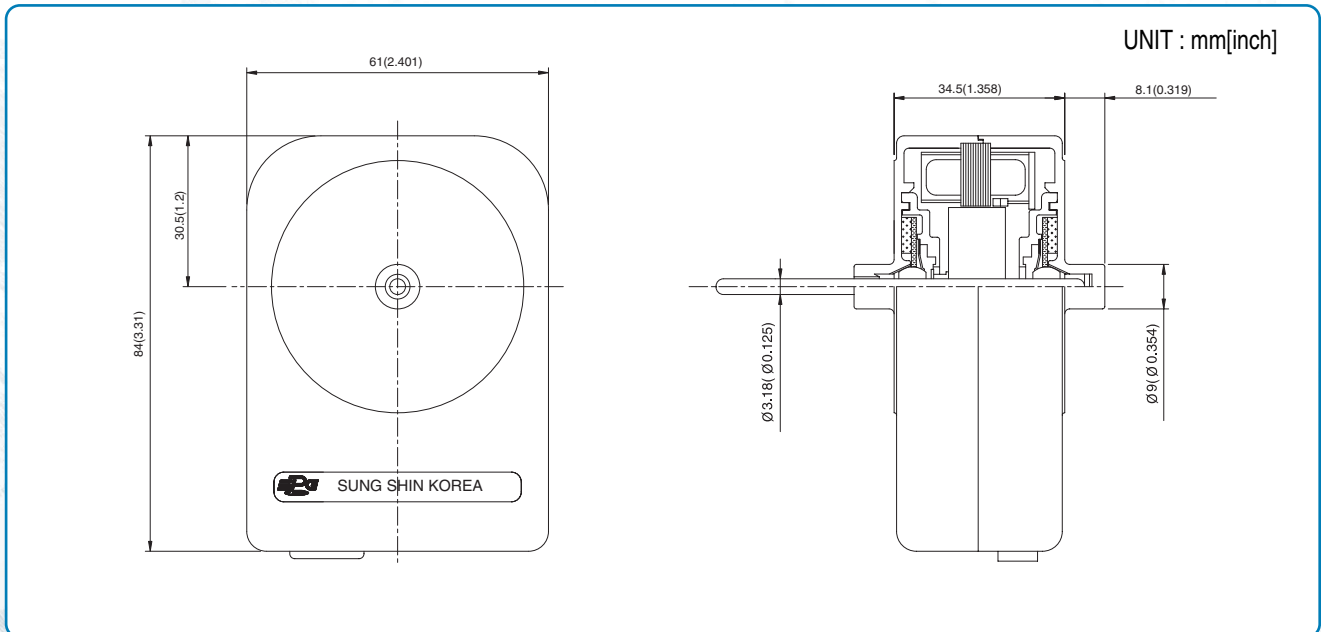

DIMENSION



CHARACTERISTIC

Type	Voltage (V)	Frequency (Hz)	Load				Ins. Class	P.C.B Of Drive	X	
			Torque		Speed (Rpm)	Input (Wi)				Output (Wo)
			(kg.cm)	(N.m)						
ADL-5846	AC 115	60	0.055	0.0054	2700	3.5	1.6	A	Internal	-
ADL-5846	AC 230	50	0.046	0.0045	2500	3.0	1.2	A	Internal	-
DL-5846	DC 12	-	0.045	0.0044	2200	3	1.0	A	Internal	-